



# Communication to Planning Commission

## Community & Economic Development

To: Planning Commission Members

From: Casey Stewart, Principal Planner

Date: December 4, 2008

CC: Paul Nielson, City Attorney Office

Re: Amendment to Autozone Brickyard Planned Development (#410-08-39)

### Attachments:

- A. Photographs
- B. Site plan & sign drawings
- C. Community Council Comments
- D. Minutes of Sept 10, 2008 PC meeting
- E. Original staff report

---

## **Request**

The Boyer Company proposes to amend the recently approved Autozone Brickyard Planned Development (410-08-39) in order to install a monument sign for the project.

## **Background**

### **Project Description**

The project site is located at approximately 1199 E. 3300 S. at the southern entrance to the Brickyard Plaza retail center. The property is in the CB zoning district. On September 10, 2008 the Planning Commission approved a planned development for a new retail building, approximately 6,000 square feet in size, to house "Autozone" an auto parts retailer. The proposal did not include any signs other than a building mounted sign on the front façade. The Boyer Company now seeks to amend the planned development to include a monument sign to be located along 3300 South. See attached sign drawings and site plan.

The planned development was approved as a "pad site", which is part of a larger 16-acre parcel on which the entire Brickyard Plaza shopping center is located. Each parcel is allowed one monument or pole sign per street frontage. There is already a tall double pole sign located near the south entrance to Brickyard Plaza along 3300 South, which sign counts as the parcel's free-standing sign (monument or pole) for the 3300 South frontage. The existing pole sign appears to be nonconforming because it exceeds the face area limits, and possible the height limit, for the CB district. Staff is unsure of the exact height and face area, but was able to determine that it is nonconforming. The height for *pole signs* is limited to 25 feet and the face area is limited to 100 square feet for a multi-business sign. In the CB district, each parcel is permitted one monument or pole sign per street frontage.

The proposed monument sign is 10 feet tall and has a sign face area of 32 square feet. It would be located 10 feet from the south lot line and two feet from the public sidewalk. All dimension aspects of the sign comply with the sign regulations.

## **Comments**

## Public Comments

The Sugar House Community Council voiced concern with allowing another sign along this portion of the Brickyard Plaza given that the existing pole sign can accommodate a number of businesses in the development. After some discussion, the community council supported a small monument sign, such as the one proposed, but prefers to limit how long it can be there. The community council supports the sign under the condition that the proposed monument sign would be removed when the existing pole sign was remodeled. See community council comments included as “Attachment C” for more detail. The conditional support is not precise in pinpointing exactly the conditions under which the monument sign should be removed. In staff’s opinion it could be difficult in the future to enforce the condition.

## City Department Comments

Comments were received from the following City departments and are included below. In general, the departments had no objections or concerns with the proposed sign.

- **Public Utilities:** No comments.
- **Engineering:** No comments.
- **Transportation (Barry Walsh):** “The sign location shown presents no impact to the required vehicular clear sight distance zone for the driveway access to 3300 South and does not encroach within the public right of way or the pedestrian sidewalk corridor.”
- **Fire (Ted Itchon):** No comments.
- **Building Services:** No comments.

## Project Review

### • Internal Project Review

Staff reviewed the request for a *monument sign* and initially considered processing it as a variance, however after further discussion, staff determined that it was more appropriate to process as a planned development amendment. The planned development process does consider signs as part of the overall development and has authority to modify sign regulations as part of that process.

The proposed sign complies with all dimensional limits for monument signs in the CB district. The only regulation it does not comply with is the number of signs allowed per street frontage for a project. In reviewing the past report for the original planned development (410-08-39) the “pad site” was treated as its own parcel with respect to landscaping and parking ordinances. The same could be applied to signs for this pad site. The pad site appears to function as its own site.

As part of the original planned development the proposed building was approved for a location 92 feet back from the front property line along 3300 South. The proposed sign would be located 14 feet from the front property line. The existing pole sign is located 10 feet from the front property line and 68 feet due east from the proposed sign. The existing pole sign’s height and closer proximity to the street arguably make it more visible than the proposed monument sign.

The standards for planned developments include one standard for signs, which is stated below as standard “H”. Refer to *page 11* of the attached staff report for the analysis of signs for the original planned development.

*“H. Signage shall emphasize the pedestrian/mass transit orientation.”*

Staff is of the opinion that the new retail use should utilize the existing pole sign shared by some of the other businesses of the Brickyard Plaza center, thereby preventing further visual sign clutter along 3300 South. Staff concurs that this pad site is somewhat separated from the larger Brickyard center and understands the applicant’s desire for an additional sign but staff finds no justification for the extra sign.

**Attachment 'A'**  
Photographs



Existing pole sign at south entrance to Brickyard Plaza (3300 South).



Staff's depiction of proposed sign size and location.

**Attachment 'B'**  
Site plan & sign drawings

© COPYRIGHT 2007

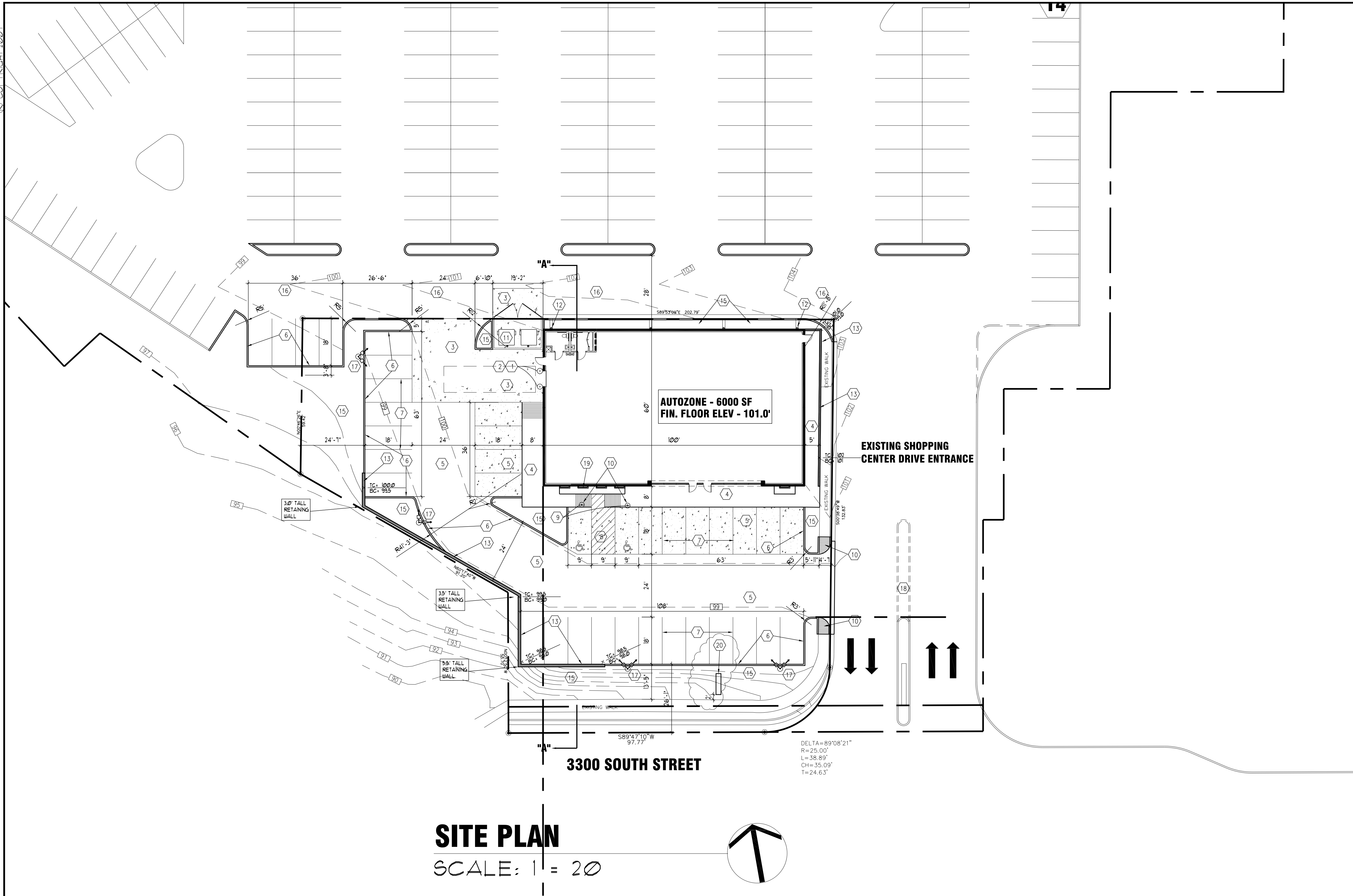

**SITE PLAN**  
SCALE: 1" = 20'

**BUILDING INFORMATION:**

OCCUPANCY - M - MERCHANTILE  
 TYPE OF CONSTRUCTION - VB  
 BUILDING SF - 6000 SF  
 SPRINKLERED - NO  
 FIRE ALARMS - NO  
 EMERGENCY LIGHTING - YES  
 NUMBER OF EXITS REQUIRED - 2  
 EXITS PROVIDED - 3  
 NUMBER OF FLOORS - 1 STORY  
 BUILDING HEIGHT - 21' MAIN PARAPET  
 PARKING SPACES REQUIRED 3/1000 = 18 SPACES  
 PARKING SPACES PROVIDED = 30  
 HC SPACES PROVIDED 2  
 TOTAL SPACES 32

**KEYNOTES**

- 1 PIPE GUARD
- 2 LOADING DOOR
- 3 CONCRETE LOADING AREA - 6" HEAVY DUTY CONCRETE
- 4 NEW 4" THICK CONCRETE SIDEWALK
- 5 5" CONCRETE PAVING
- 6 CONCRETE CURB & GUTTER
- 7 4" WIDE PARKING STRIPE PAINTED WHITE (TYP)
- 8 4" WIDE DIAGONAL STRIPES PAINTED WHITE @ 2' O.C.
- 9 ACCESSIBLE PARKING SIGN
- 10 CONCRETE ACCESSIBLE RAMP - MAXIMUM SLOPE 1:12 (8.33%)
- 11 TRASH ENCLOSURE
- 12 ROOF DRAIN OUTLET LOCATION PROVIDE CONCRETE SPLASHBLOCK.
- 13 POURED CONCRETE RETAINING WALL WITH HANDRAIL
- 15 LANDSCAPE AREA
- 16 NEW ASPHALT PAVING
- 17 NEW SITE LIGHTS - 400W METAL HALIDE
- 18 REWORK MEDIAN TO ALLOW LEFT-IN ACCESS
- 19 METAL TRELLIS WORK
- 20 MONUMENT SIGN LOCATION

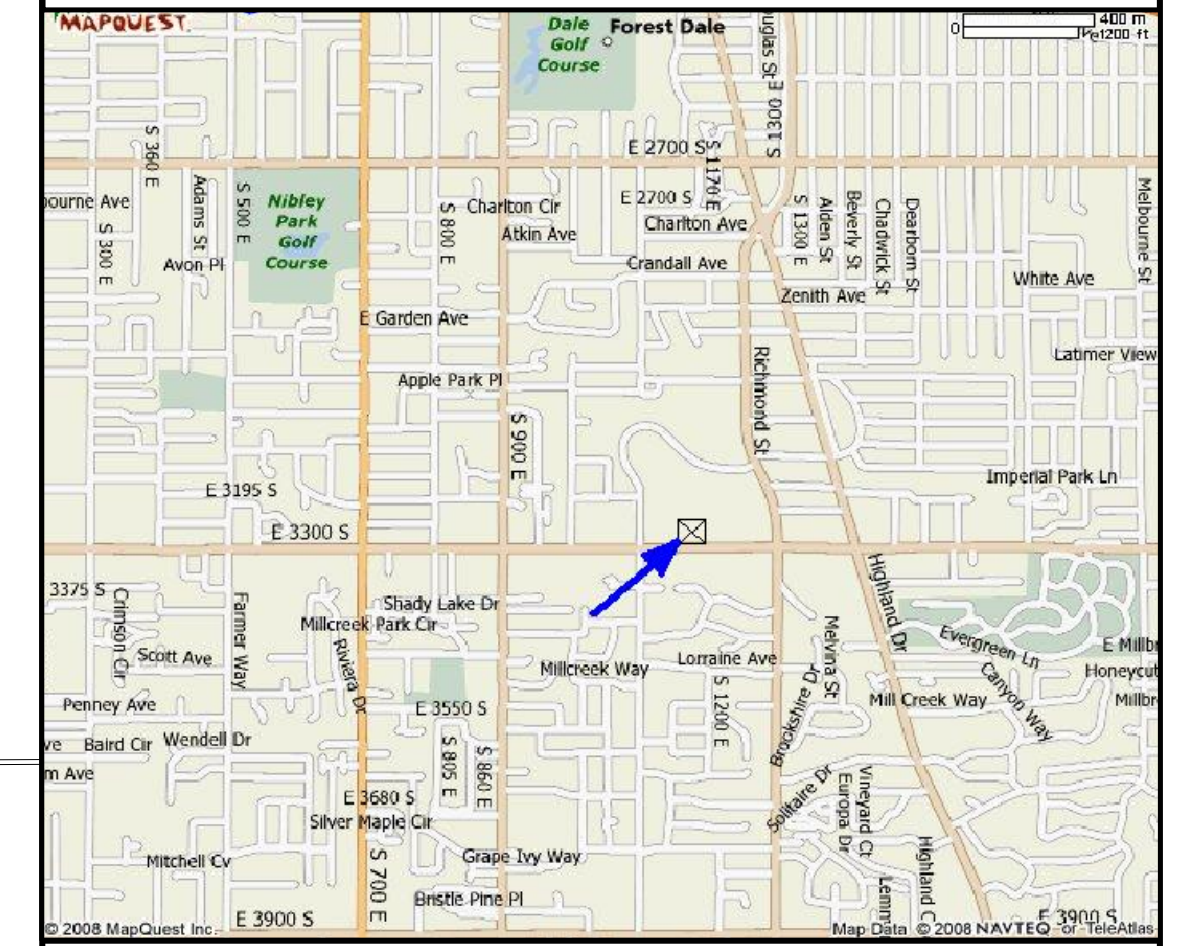

VICINITY MAP

REVISIONS	1	2	3	4	5	6

AutoZone Store No. E181  
 3300 SOUTH STREET  
 SALT LAKE CITY UT  
**ARCHITECTURAL SITE PLAN**

Architect: LEW ELLIS  
 123 South Front Street  
 Memphis, Tennessee 38103  
 TEL: 495-8714 FAX: (901) 495-8969

04-09-08

**C1**

**PAD C - BRICKYARD PLAZA SHOPPING CENTER**  
 SALT LAKE CITY, UT.

**PARCEL DESCRIPTION:**

BEGINNING AT A POINT ON THE NORTH RIGHT OF WAY LINE OF 3300 SOUTH STREET, SAID POINT BEING SOUTH 00°02'10" WEST 1493.77 FEET AND SOUTH 89°47'10" WEST 1262.56 FEET FROM THE EAST QUARTER CORNER OF SECTION 29, TOWNSHIP 1 SOUTH, RANGE 1 EAST, SALT LAKE BASE AND MERIDIAN, RUNNING THENCE SOUTH 89°47'10" WEST 97.78 FEET ALONG SAID RIGHT OF WAY LINE, THENCE NORTH 0°12'50" 12'50" WEST 53.70 FEET; THENCE NORTH 60°17'40" WEST 91.20 FEET; THENCE NORTH 0°46'26" EAST 59.42 FEET THENCE SOUTH 89°53'09" EAST 202.79 FEET; THENCE SOUTH 0°38'49" WEST 132.83 FEET TO A POINT ON A 25.00 FOOT RADIUS CURVE TO THE RIGHT; THENCE 38.89 FEET ALONG THE ARC OF SAID CURVE THROUGH A CENTRAL ANGLE OF 89°08'21" TO THE POINT OF BEGINNING.  
 CONTAINS 25,818 SQ.FT. OR 0.593 ACRES.

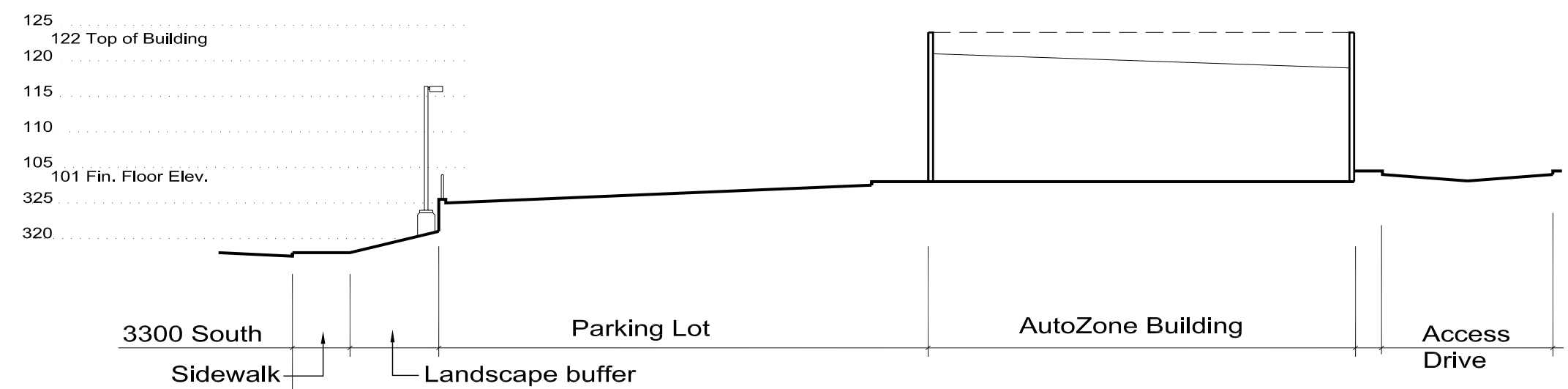

**SITE SECTION "A"**

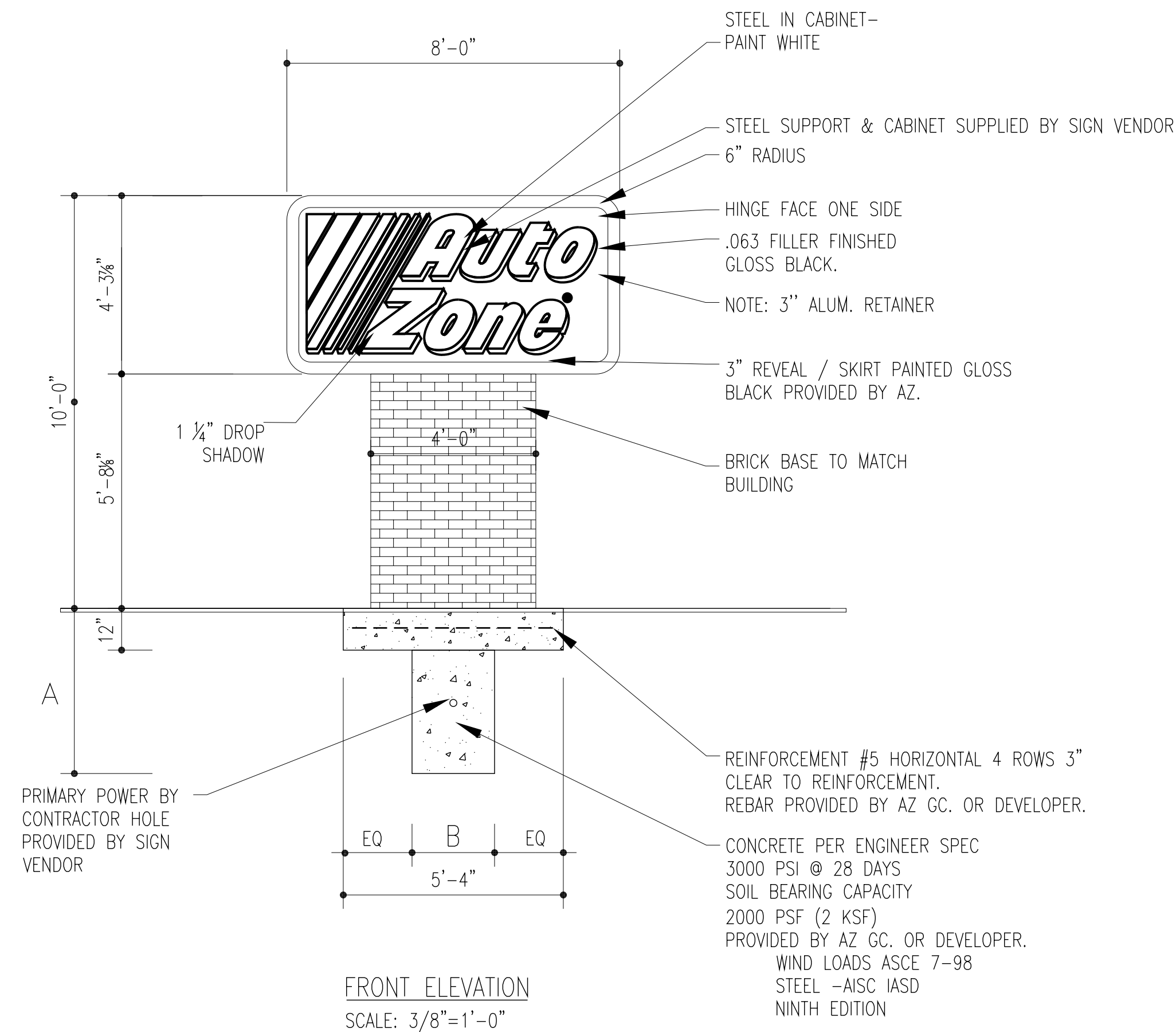

PRIMARY POWER BY CONTRACTOR HOLE PROVIDED BY SIGN VENDOR

REINFORCEMENT #5 HORIZONTAL 4 ROWS 3" CLEAR TO REINFORCEMENT. REBAR PROVIDED BY AZ GC. OR DEVELOPER.

CONCRETE PER ENGINEER SPEC 3000 PSI @ 28 DAYS SOIL BEARING CAPACITY 2000 PSF (2 KSF) PROVIDED BY AZ GC. OR DEVELOPER. WIND LOADS ASCE 7-98 STEEL -AISC IASD NINTH EDITION

BLOCK STYLE FOUNDATION			FOUNDATIONS		
WIND LOADS	STEEL IN CABINET	STEEL SUPPORT	A-DEPTH	B-FRONT	C-SIDE
EXPOSURE B-100 MPH	4" DIA. X .237 WALL	4" DIA. X .237 WALL	3'-0"	2'-0"	2'-0"
CONCRETE APPROX. .444 CU. YD.					

BLOCK STYLE FOUNDATION ENGINEERING SPECIFICATIONS BASED ON 100 MPH WIND LOAD

**GENERAL SPECIFICATIONS:**  
D/F ILLUMINATED MONUMENT SIGN:

**CABINET:** FABRICATED OF EXTRUDED ALUMINUM W/ ALUMINUM COMPONENTS.

**FACES:** ARLON\SIGNTECH HEAT TRANSFERRED FLEX FACE® WITH FX CLEARCOAT PROTECTION COATING AND 3" CLIPS FOR TENSIONING.

**ILLUMINATION:** H.O. FLUORESCENT LIGHTING POWERED BY ELECTRONIC BALLAST.

**ELECTRIC:** 120 VOLT 20 AMP PRIMARY ELEC. CKTS BROUGHT TO SIGN & FINAL HOOK UP BY AZ GC.

**SUPPORT:** STEEL PIPE & CONCRETE FOUNDATION PER ENGINEERS SPEC.

**COLORS:** CABINET-----GLOSS BLACK  
SIGN FACE-----WHITE  
"AUTOZONE"-----RED (ARLON #PX2662) (PMS #485)  
"STRIPING"-----ORANGE (ARLON #PX2119) (PMS #165)  
DROP SHADOW-----BLACK (ARLON #PX2025)  
Ⓞ-----RED (ARLON #PX2662) (PMS #485)

**AUTHORITY:** SEE N. E. C. ARTICLE 600. ALL PRIMARY CONNECTIONS ARE TO BE MADE BY LICENSED ELECTRICAL CONTRACTORS.

**PRIMARY ELECTRICAL:** ALL PRIMARY ELECTRICAL CONNECTIONS ARE TO MEET OR EXCEED N.E.C. U.L. 48 OR LOCAL ENFORCING

**PRIMARY WIRING:** SHALL BE (3) #12 THW/THWN (BY OTHERS). GROUNDING PER. NEC ARTICLE 250 (BY OTHERS).

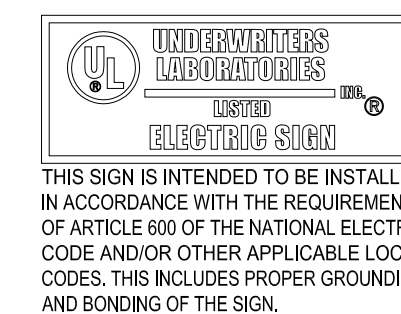
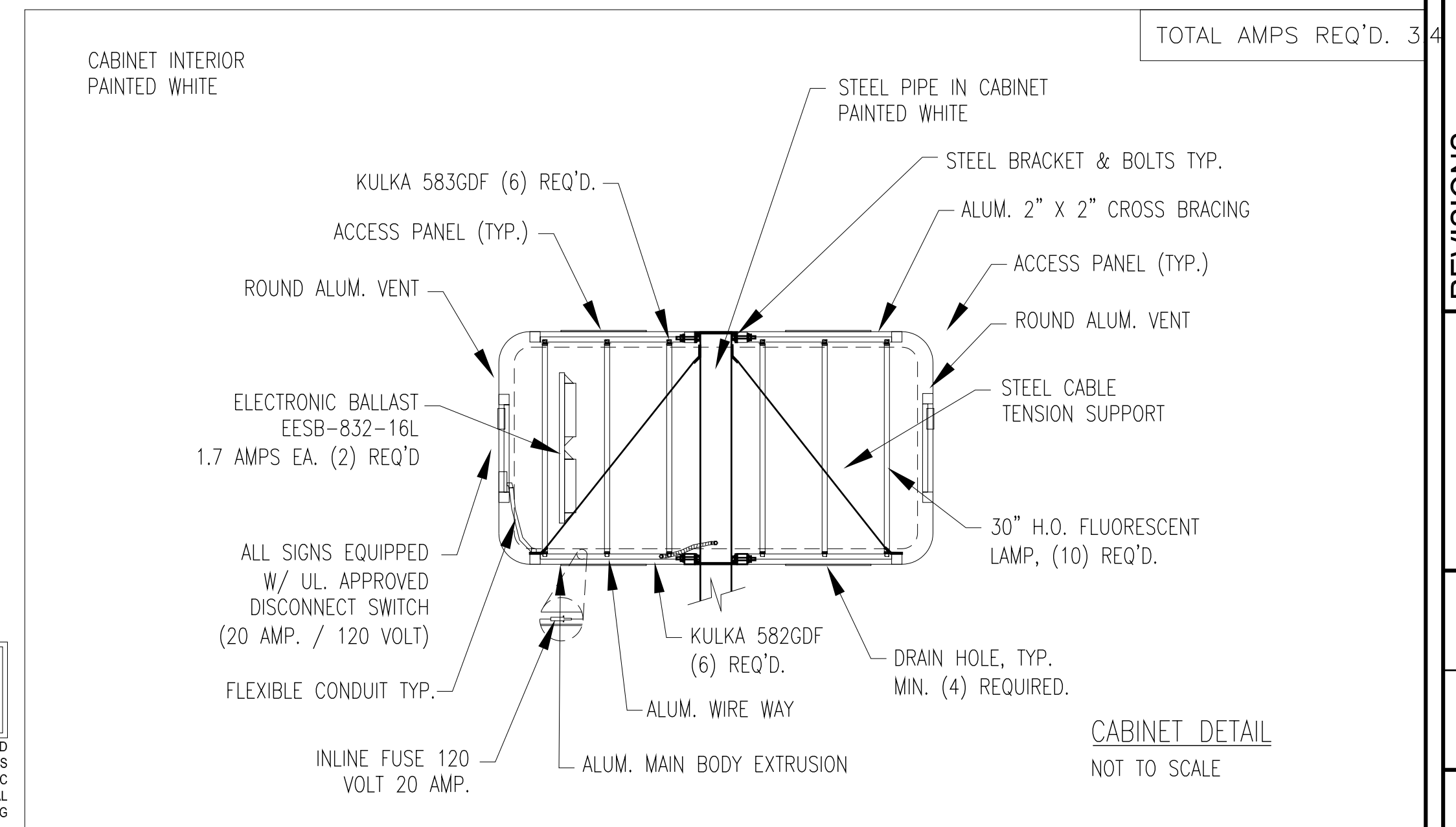
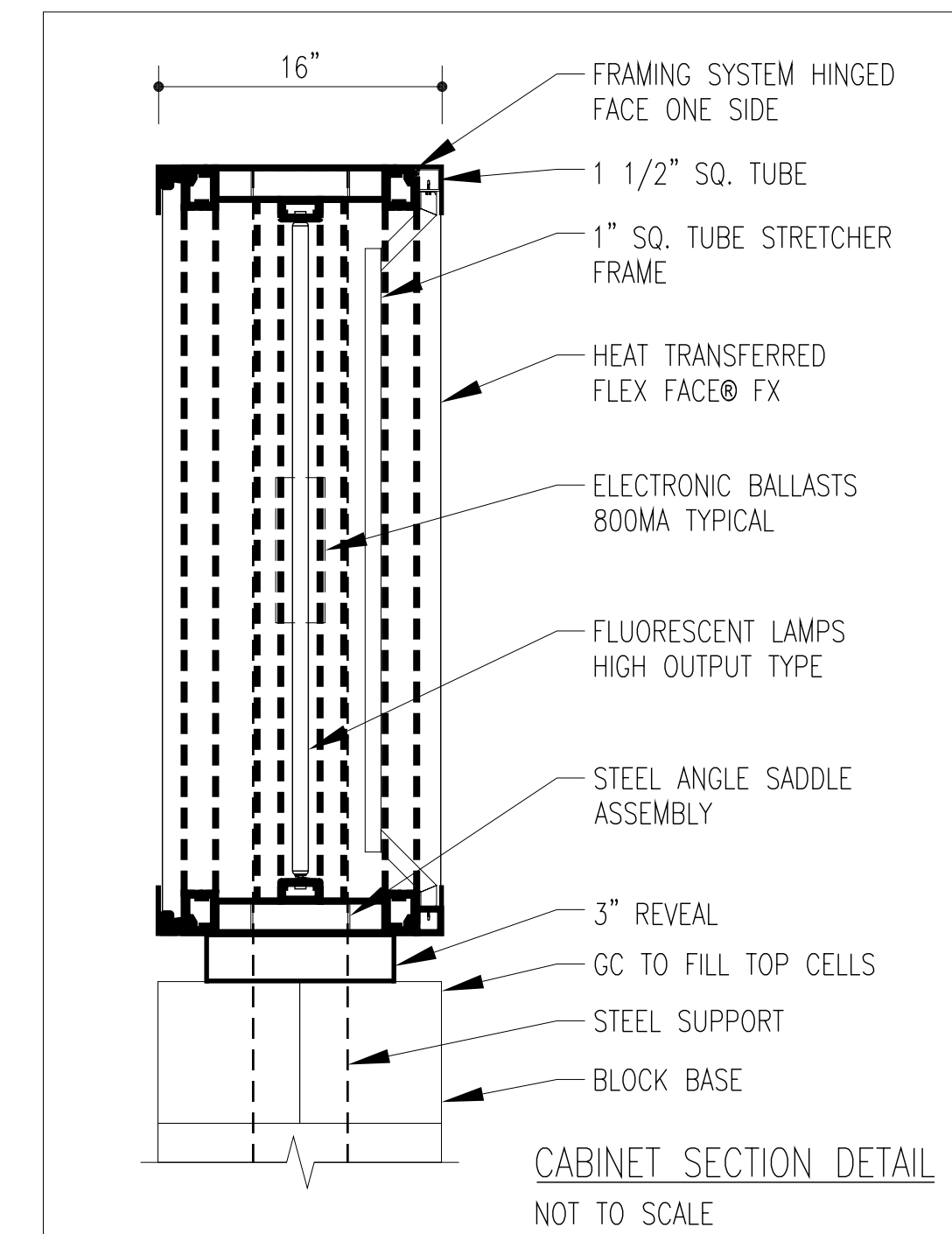

THIS SIGN IS INTENDED TO BE INSTALLED IN ACCORDANCE WITH THE REQUIREMENTS OF ARTICLE 600 OF THE NATIONAL ELECTRIC CODE AND/OR OTHER APPLICABLE LOCAL CODES. THIS INCLUDES PROPER GROUNDING AND BONDING OF THE SIGN.

**AutoZone, Inc.**  
123 South Front Street  
Memphis, Tennessee 38103  
TEL: (901) 495-8706 FAX: (901) 495-8424

**AutoZone STORE DEVELOPMENT**  
Prepared For: Store No. 4207 3762  
SALT LAKE CITY UT 84124  
10' MONUMENT SIGN

REVISIONS	DATE	BY	DESCRIPTION
1.			
2.			
3.			
4.			

DATE  
09-23-08  
PROTOTYPE SIZE

65W2

**SN-3**

**Attachment 'C'**  
Community Council comments





**Sugar House  
Community Council**

November 11, 2008

TO: Casey Stewart  
FROM: Judi Short, Land Use Committee, Sugar House Community Council  
RE: AUTOZONE Store at the Brickyard

Recently, Nate Swain came back to the Sugar House Land Use Subcommittee and requested an additional sign for Auto Zone. This is to be a monument sign along 33<sup>rd</sup> South, which is in addition to the large sign that is already at the 33<sup>rd</sup> South entrance to the Brickyard. That sign does not have space on it to add AutoZone. Mr. Swain indicated that as Mervyn's closes and is replaced by another tenant, and the gym gets new tenants, there will be some re-working of the south and west edge of the mall. Once the tenants are firm, they intend to replace the large sign, and at that time they will add the AutoZone to the big sign, and remove the smaller monument sign. Here is the motion recommended by the subcommittee and approved by the Sugar House Community Council at the November 3 meeting of the council.

"The Sugar House Land Use and Zoning Committee moves to accept the AutoZone monument sign request by the Boyer Company as presented in their documents, with the stipulation that when the entire mall's tower signage on 33rd South is updated, the AutoZone signage will be incorporated within that signage and the monument sign (in question) removed. The Boyer Company is to provide a letter to the City's file stating this intent.

The intent of this motion is to urge the developer to put some equity into visually cleaning up this mall, and to reduce the visual clutter on 33rd South. When the mall's tower sign is updated and improved, signifying its new tenants, it should incorporate all the adjacent businesses and allow the removal of single monument signs in the area."

Will you please make sure that Boyer puts such a letter in the project file, and that the monument sign comes down at the proper time? Thank you. If you have questions, you can call me at 801-487-7387.

**Attachment 'D'**  
Minutes of Sept 10, 2008 PC meeting

**SALT LAKE CITY  
PLANNING COMMISSION MEETING  
In Room 315 of the City & County Building  
451 South State Street, Salt Lake City, Utah  
Wednesday, September 10, 2008**

Present for the Planning Commission meeting were Chair Matthew Wirthlin, Vice Chair Mary Woodhead and Commissioners: Robert Forbis, Peggy McDonough, Babs De Lay, Kathy Scott, Susie McHugh, Tim Chambless, and Frank Algarin. Commissioner Prescott Muir was excused from the meeting.

Present from the Planning Division: Wilf Sommerkorn, Planning Director; Joel Paterson, Acting Deputy Director; Paul Nielson, Senior City Attorney; Lex Traughber, Senior Planner; Nick Britton, Principal Planner; Katia Pace, Associate Planner; Casey Stewart, Principal Planner; Kevin Young, Transportation Planning Engineer; and Tami Hansen, Planning Commission Secretary.

A roll is being kept of all who attended the Planning Commission Meeting. Chair Wirthlin called the meeting to order at 5:47 p.m. Audio recordings of the Planning Commission meetings are retained in the Planning Office for an indefinite period of time.

A field trip was held prior to the meeting. Planning Commissioners present were: Frank Algarin, Tim Chambless, Kathy Scott, Matthew Wirthlin, and Mary Woodhead. Staff members present were: Lex Traughber, Joel Paterson Katia Pace, and Casey Stewart.

**12:15:19 AM Petition 410-08-39 AutoZone Planned Development**—a request by The Boyer Co., represented by Nate Swain, to construct a new 6,000 square foot commercial building on a pad site located at approximately 1199 East 3300 South, at the south entrance of the Brickyard Plaza, in a Community Business (CB) district. The property is located in City Council District Seven, represented by Søren Simonsen.

Chair Wirthlin recognized Casey Stewart as staff representative.

Mr. Paul Neilson noted that he might have a conflict of interest because the president of the company making the request was a personal acquaintance, and inquired of the Commission if they felt he needed to recuse himself.

The Commissioners agreed that there was no conflict of interest and Mr. Neilson should stay for the final petition.

**12:35:15 AM Public Hearing**

The following person spoke or submitted hearing card in support of the proposed petition: **Grace Sperry, Sugar House Community Council Chair** (2660 South Highland Drive).

**12:43:28 AM Vice Chair Woodhead made a motion regarding Petition 410-08-39, the Autozone planned development, a request for preliminary planned development approval, based on the staff report, testimony and discussion before the Commission, the Planning Commission recommends approval of the planned development and finds that it satisfies the standards for approval subject to the following conditions:**

1. **Compliance with the departmental comments as outlined in the staff report.**
2. **Final approval is hereby delegated to the Planning Director subject to certification by the planning director that the final development plan is in conformance with the preliminary development plan approved by the planning commission; and**
3. **The metal trellises as shown on the front facade, marked as figure twenty-one (21), are increased to the maximum extent possible and planters provided in front from which to grow ivy intended to climb the trellises; with final approval by the Planning Director.**

**And allowed modifications:**

1. Extension of the maximum front yard building setback from 15 feet to 92 feet as shown on the landscape plan.
2. Reduction from 7 feet down to 5 feet for width of required landscape buffer along the west edge of the west parking area that is within 7 feet of the property line as shown on the applicant's landscape plan.
3. Grade changes up to, but not more than, 6 feet for the proposed retaining wall along 3300 South.
4. Front façade glass content requirement reduced from 40% to 24% as shown on the building elevation plan.
5. Required 5% interior parking lot landscaping reduced to 2% as shown on the landscape plan.
6. Parking in the front yard as shown on the landscape plan.

**Seconded by Commissioner Algarin.**

Discussion of the Motion

Commissioner McDonough stated that there was a lot of impervious pavement around this development, and she felt the Commission was encouraging that to happen, because future retailers did not have to comply.

Vice Chair Woodhead stated that the reason why the Boyer Company was not complying was because of existing lease documents, which create the impediment.

**Commissioners McHugh, Chambliss, Algarin and Vice Chair Woodhead, voted, "Yes". Commissioners Forbis, Scott, and McDonough voted, "No". The motion passed.**

**Attachment 'E'**  
Original Staff Report



Planning and Zoning Division  
Department of Community &  
Economic Development

**Autozone Planned Development**  
Preliminary Planned Development (Petition 410-08-39)  
Located at approximately 1199 East 3300 South  
Hearing date: September 10, 2008

**Applicant:**

The Boyer Company  
Nate Swain

**Staff:**

Casey Stewart 535-6260  
casey.stewart@slcgov.com

**Tax ID:**

16-29-427-042

**Current Zone:**

CB (Community Business)

**Master Plan Designation:**

Sugar House Master Plan:  
High Intensity Mixed Use

**Council District:**

District 7 – Søren Simonsen

**Lot size:** 16 acres

**Current Use:**

Vacant, unimproved pad site of  
Brickyard Shopping Center

**Applicable Land Use Regulations:**

- Chapter 21A.26.030 CB District
- Chapter 21A.54.150 Planned Development

**Attachments:**

- A. Applicant's Project Description
- B. Site/Building drawings
- C. Site Photographs
- D. Department comments
- E. Public/Community Council Comments
- F. PC Subcommittee notes
- G. Previous design approved 2003

**REQUEST**

This is a request by The Boyer Company for preliminary approval to build a new principle building on an existing pad site in an existing retail center. The proposal consists of a new 6,000 square foot retail store at approximately 1199 East 3300 South. The planned development application is for modifications to building setback, parking setback, glass content, landscaping requirements, and grade changes.

**PUBLIC NOTICE**

On August 26, 2008 a notice of public hearing was mailed to all property owners within 450 feet of the subject property. On August 28, 2008 the site was posted with a notice of public hearing sign. Both the mailed and posted notice comply with noticing requirements of the City Ordinance. Community Council Chairs, Business Groups and other interested parties were notified through the Planning Division's listserv. The Planning Commission agenda was posted on the Planning Division's web page.

**PUBLIC COMMENTS**

This request was reviewed by the *Sugar House Community Council* at their July 2, 2008 meeting. The community council discussion focused on the setback of the building, the minimal glass content, and the site's interaction with the larger Brickyard retail center. Overall, the council did not support the project as proposed.

**STAFF RECOMMENDATION:**

Staff finds the Conditional Use/Planned Development application by The Boyer Company (petition #410-08-39) sufficiently satisfies the standards for approval (21A.59.060) and therefore recommends approval subject to the following conditions:

Conditions of approval:

1. Compliance with the departmental comments as outlined in this staff report.
2. Final approval is hereby delegated to the Planning Director subject to certification by the planning director that the final development plan is in conformance with the preliminary development plan approved by the planning commission.
3. Replace the proposed 12 parking stalls located closest to 3300 South with landscaping in compliance with City landscaping regulations.

**Allowed modifications:**

1. Extension of the maximum front yard building setback from 15 feet to 92 feet as shown on landscape plan.
2. Reduction from 7 feet down to 5 feet for width of required landscape buffer along west edge of west parking area that is within 7 feet of property line as shown on the applicant's landscape plan.
3. Grade changes up to but not more than 6 feet for the proposed retaining wall along 3300 South.

# VICINITY MAP

1199 E. 3300 S.



## **Overview**

The project site is located at approximately 1199 E. 3300 S. at the southern entrance to the Brickyard Plaza retail center. The property is in the CB zoning district. The Boyer Company desires to construct a new retail building, approximately 6,000 square feet in size, to house “Autozone” an auto parts retailer. The proposal is being processed through the Conditional Use/Planned Development review because the applicant seeks modification to requirements of the CB district related to: the maximum front setback, parking lot setback and associated landscaping, front facade glass content, and grade change limits.

A separate subdivision application to create a separate lot for this building is also being processed through the Planning Division. The applicant has indicated they may withdraw subdivision application because of city requirements related to improvements on the remaining larger Brickyard lot. The applicant claims the required improvements would cost too much to justify creating a separate lot for the Autozone building.

Without the creation of a separate lot, the development site defaults to the existing parcel which contains the entire parking lot for the existing center; the existing buildings at the Brickyard center are each on separate parcels. This parking lot parcel is approximately 16 acres in size. However, the proposed building site is visually and logistically separated from the larger retail center. It has always been considered a “pad” site to be developed on its own. The entire parcel would typically be subject to all the site design requirements for the CB district and for parking lots including perimeter parking lot landscaping, interior parking lot landscaping, parking lot setbacks, etc. However, as part of the Planned Development, the applicant is requesting that all site design requirements be based solely on the pad site area. Staff supports this premise and the analysis provided is based on the pad site, not the entire parcel. A similar development application was approved in 2003 following this same premise.

In 2003 the Planning Commission approved a new building for this pad site. Approval was based on the building being located closer to 3300 South, approximately 23 feet from the front property line. The façade along 3300 South was considered the rear of the building but was required to include significant transparent glass. The north façade was the primary façade and was oriented to the parking lot located to the north. This building location required a retaining wall approximately 11 feet at its tallest point along 3300 South. After approval, the applicant never pursued the project due to high costs related to the retaining wall needed to support the building.

## **Existing Conditions**

The proposed site is a vacant, unimproved area at the south entrance of the Brickyard Plaza retail center. The site has been intended for a 6,500 square foot retail pad, but has been vacant since construction of the Brickyard center began in the late 1970’s. The site is void of vegetation and slopes down from the northeast to southeast corners. The site is bordered: on the north by the parking lot for Brickyard Plaza, on the east by the entrance drive aisle into the Brickyard Plaza center, on the south by 3300 South, and on the west by vacant property.

## **Discussion**

The following discussion identifies and clarifies the specific reasons for Planned Development Review of this project and staff’s consideration of each reason. The requirements discussed come from the CB zoning district and City landscaping ordinances for parking lots.

- **Maximum Building Setback (21A.26.030.F.6):** A maximum setback of 15 feet is required for at least seventy five percent (75%) of the building façade. In this case, the setback applies to 3300 South. The applicant claims an economic hardship in response to this requirement. A project was approved for this site in January 2003 (petition 410-617, see attached Exhibit G) that called for the building to be located closer to 3300 South and the parking lot located north of the building. However, the applicant claims that the cost to fill the area of the building and construct an engineered retaining wall strong enough to support



the extra fill and building was cost prohibitive in as much as the businesses proposed for the site could not afford the higher lease.

The applicant proposes to move the building north on the site and place the parking in front (south side). This scenario allows for the parking lot to slope down toward 3300 South and use up some of the grade change, thus requiring less of a retaining wall (5 feet instead of 11+ feet) at the sidewalk. The proposed retaining wall would be terraced and landscaped.

- **Parking Setback (21A.26.030.F.7):** The CB zoning district prohibits parking in the front and corner side yards. No front yard is required; however, when one is provided as is the case with the proposed Autozone building, it must comply with all regulations applicable to front yards. This includes the requirement that the front yard shall be maintained as a landscape yard. In this case, a terraced, landscaped retaining wall and parking stalls are proposed to be located in the front yard along 3300 South, between the street and the building.

To avoid both locating the parking in the front yard and the costs for the retaining wall, the applicant could locate the building on the northern portion of site as proposed but landscape the entire front yard area between the building and 3300 South. The customers could utilize the existing parking located north of the building. This option would eliminate the need for a retaining wall along 3300 South. The applicant disproves of this option because of parking requirements established by the leases for the existing Brickyard tenants. The leases require that this pad site provide exactly the amount of additional parking proposed by the applicant.

Another consideration is to reduce to number of parking stalls, possibly the southern most row of stalls, since the project is proposing more than required by City ordinance. Reducing the number or parking stalls would allow for additional landscaping in an effort to mitigate the larger setback. Again, the applicant claims parking terms in the existing leases for the Brickyard center preclude reducing the number of stalls. Staff prefers this option and has incorporated it into the recommendation.

- **Minimum First Floor Glass (21A.26.030.I.1):** The building facade facing 3300 South is required to have a minimum of forty percent (40%) non-reflective glass. The proposed façade contains approximately twenty-four percent (24%) glass.

The applicant has revised the building design to include more non-reflective glass up to twenty-four percent (24%) glass. The applicant claims that the amount of glass has to be limited because this type of retail use inventories a larger number of items and needs interior wall space to do so. Due to the glass content requirement, large inventory retail businesses such as this auto parts store will find difficulty in meeting the glass requirement.

Staff discussed the option of using display type windows to increase the amount of transparent glass on the front façade. The applicant deemed this ineffective because auto parts stores do not typically display parts in a window. Staff's opinion is that the building design should one way or another incorporate the required amount of transparent glass on the front façade.

- **Perimeter Parking Lot Landscaping (21A.48.070.C.2):** When parking is proposed within a required yard or within twenty feet (20') of a lot line, perimeter landscaping shall be provided. The landscaping shall be provided with landscape areas at least seven feet (7') wide measured from the back of the parking lot curb. The proposed parking lot is five (5') feet from the interior side (west) lot line. The proposed landscape area is five feet rather than seven feet (7').

Given the vacant, undevelopable lot located to the west of the site, staff finds the enforcement of the 7-foot perimeter landscaping unnecessary in this location along the west property line.

- Interior parking lot landscaping (*21A.48.070.B.1*): Not less than 5% of the interior of a parking lot shall be devoted to landscaping. Using the pad site area, the parking lot proposed by the applicant includes landscaped areas at the end of the parking rows. Landscaping also needs to be included interior to the parking lot. The landscaped area at the southwest corner of the building is approximately 190 square feet in size and counts toward the interior landscaped area; however, to reach the 5% mark of 440 square feet, additional landscaping is needed. This could be achieved by converting two parking stalls to landscaped areas – preferably two stalls in the south parking lot. Another option to resolve the landscaping would be to replace the 12 parking stalls along 3300 South with landscaping, since the proposed number of stalls exceeds the City requirement by approximately 13 stalls – this is included as a recommended condition of approval.
- Grade change (*21A.36.020.B*): Grade changes of more than two feet (2’) can only be approved as a variance or as part of a planned development. In this project, the proposed retaining wall along 3300 South will facilitate a grade change of approximately 5 feet per the applicant’s description. This will be accomplished with two terraced walls with landscaping on the terrace. Given the existing topography of the site, altering the grade more than two feet will always be needed when developing this parcel.

## **Comments**

### **Community Council comments {Attached as Exhibit ‘E’}**

The Sugar House Community Council voiced concern with the building design, particularly the north and east facades, and what the council perceived as a lack of pedestrian emphasis and connectedness with the larger Brickyard center to the north. The applicant has revised the building facades to include more detailing and included additional plants in the landscaping on the north side of the building to break up the north façade. No revisions were made in response to the pedestrian access. The applicant considers the proposed pedestrian circulation adequate. See the council comments in “Attachment E”.

### **Public Comments**

No citizen comments were received.

### **Planning Commission Subcommittee comments {Attached as Exhibit ‘F’}**

A subcommittee of the Planning Commission met on July 16, 2008. Commissioners Babs De Lay, Mary Woodhead, and Kathy Scott attended and generally supported the development as proposed subject to additional building design features, such as glass blocks, that would add more life to the building and prevent distances of more than 15 feet without some design feature.

### **City Department Comments {Attached as Exhibit ‘D’}**

Comments were received from the following City departments:

- Engineering
- Transportation
- Fire
- Building Services

In general, the departments had no objections or concerns with the proposed development. The departments provided specific improvements required according to their respective oversight. See their attached comments for details.

## **Staff Analysis (Conditional Uses; Section 21A.54.080)**

- A. General Standards for Approval: A conditional use shall be approved if reasonable conditions are proposed, or can be imposed, to mitigate the reasonably anticipated detrimental effects of the proposed use in accordance with applicable standards. If the reasonably anticipated detrimental effects of a proposed conditional use cannot be substantially mitigated by the proposal or the imposition of reasonable conditions to achieve compliance with applicable standards, the conditional use may be denied.

In order to identify and evaluate the detrimental effects and the need for and/or adequacy of mitigating conditions, the Planning Commission shall review and consider the following:

#### Approval of Conditional Use Application

##### 1. Master Plan and Code Compliance

- A. *The proposed development is supported by the general policies of the City Wide, Community, and Small Area Master plan text and the future land use map policies governing the site;*

**Analysis:** The proposed development is within the Sugar House Master Plan area and property designated for High Intensity – Mixed Use. The objective and general policy for this type of designation is to allow integration of residential with business uses and support more walkable community development patterns located near transit lines and stops.

The subject site is currently vacant and unimproved. It is part of the larger Brickyard retail shopping center. The proposed use retail use is supported by the future land use map. The proposed retaining wall is shorter than would be necessary if the building were located closer to 3300 South. A shorter wall creates for better pedestrian visibility from 3300 South and reduces the amount of blank wall space. The proposed landscaping serves to soften the edges of the development and incorporate more green space into the existing Brickyard center. This particular site being located adjacent to 3300 South, has limited potential as a heavily used pedestrian corridor but is next to a bus route. The proposed development attempts to reach a compromise between pedestrians, automobile customers, and customers accessing the larger Brickyard development.

**Finding:** The project satisfies this standard.

- B. *The proposed development is one of the conditional uses specifically listed in this title; and*  
**Analysis:** The proposed retail store is a permitted use in the CB district. Planned Developments are processed as conditional uses per the City ordinance.

**Finding:** The project satisfies this standard.

- C. *The proposed development is supported by the general purposes and intent of the zoning ordinance including the purpose statement of the zoning district.*

**Analysis:** The purpose of the ‘CB’ Community Business district is “to provide for the close integration of moderately sized commercial areas with adjacent residential neighborhoods. The design guidelines are intended to facilitate retail that is pedestrian in its orientation and scale, while also acknowledging the importance of transit and automobile access to the site.” The proposed use is part of the larger Brickyard retail shopping center. It is located in a predominantly commercial area and the design attempts to accommodate pedestrians - with a short retaining wall, landscaping, and a sidewalk leading from 3300 South - and automobiles. The nearest residential use is located on the south side of 3300 South and consists of three new multi-family buildings.

**Finding:** The project satisfies this standard.

## 2. Use Compatibility

The proposed use at the particular location is compatible with the character of the site, adjacent properties, surrounding neighborhoods, and other existing development. In determining compatibility, the Planning Commission may consider the following:

- A. *Streets or other means of access to the proposed development are suitable and adequate to carry anticipated traffic and will not materially degrade the service level on the adjacent streets;*

**Analysis:** Access to the site will primarily be gained from 3300 South, an arterial road, which is suitable and adequate to carry the anticipated traffic. Access can also be gained through the parking lot of the Brickyard center.

**Finding:** The project satisfies this standard.

- B. *The type of use and its location does not create unusual pedestrian or vehicle traffic patterns or volumes that would not be expected with the development of a permitted use. In determining unusual patterns, the Planning Commission shall consider:*

**Finding:** The proposed retail use is permitted in the CB zoning district and the City's Transportation Division deemed the existing streets and access as adequate for the proposed project. The project satisfies this standard. See analyses that follow.

- i) *The orientation of driveways and if they direct traffic to the major streets or local streets, and, if directed to the local streets, the impacts to the safety, purpose, and character of the local streets;*

**Analysis:** The driveway from the pad site leads to the shopping center drive and not to a public street. Traffic from the pad site, after entering the shopping center drive is directed south to 3300 South. The public currently utilizes the shopping center driveway to gain access to Brickyard Plaza from the south. No unusual traffic patterns or conflicts will be generated by this proposed use. The south entrance to the larger retail center is used much less frequently than the entrances located along Brickyard Road to the north. This south driveway has the capacity to handle the proposed retail store traffic.

- ii) *Parking locations and size, and if parking plans encourage street side parking to the proposed use which impacts the adjacent land uses;*

**Analysis:** The proposed parking lot is located on site and does not utilize street side parking.

- iii) *Hours of peak land use when traffic to the proposed use would be greatest and that such times and peaks would not impact the ability of the surrounding uses to enjoy the use of their properties; and*

**Analysis:** Traffic impacts generated by this proposed use will not impact ability of surrounding commercial uses to enjoy their property.

- iv) *The hours of operation of the proposed use when compared with the hours of activity/operation of the surrounding uses and the potential of such hours of operation do not create noise, height, or other nuisances not acceptable to the enjoyment of existing surrounding uses or common to the surrounding uses.*

**Analysis:** The proposed use has hours of operation of approximately 8:00 AM to 9:00 PM that are comparable to other surrounding retail uses. The proposed hours will not create any nuisances for surrounding properties.

- C. *The internal circulation system of the proposed development is properly designed for motorized, non-motorized and pedestrian traffic, and mitigates impacts on adjacent properties;*

**Analysis:** The proposed internal circulation system is designed for motorized traffic and pedestrian access via sidewalks. Given the small scope of this project, staff recommends that pedestrian circulation for the rest of the adjoining Brickyard center be addressed at some future time when the larger facility is redeveloped.

**Finding:** The project satisfies this standard.

- D. *Existing or proposed utility and public services are adequate for the proposed development and are designed in a manner that will not have an adverse impact on adjacent land uses or resources; and*

**Analysis:** Existing and proposed utility and public services have been deemed adequate by the City's Public Utilities Department.

**Finding:** The project satisfies this standard.

- E. *Appropriate buffering such as landscaping, setbacks, and building location, is provided to protect adjacent land uses from light, noise and visual impacts.*

**Analysis:** The surrounding land uses are commercial, so light and noise will be similar to what is emanated from adjacent users. The visual impact of a new building at this site will be accompanied with additional landscaping.

**Finding:** The project satisfies this standard.

- F. *Detrimental concentration of existing non-conforming or conditional uses substantially similar to the use proposed. The analysis is based on an inventory of uses within a quarter mile radius of the subject property.*

**Analysis:** The conditional use is for Planned Development stemming from requested modifications to design criteria. The proposed use itself is permitted in the CB zoning district.

**Finding:** This standard is not considered applicable in this case.

### 3. Design Compatibility

The proposed conditional use is compatible with:

- A. *The character of the area with respect to: site design and location of parking lots, access ways, and delivery areas; impact on adjacent uses through loss of privacy, objectionable views of large parking or storage areas; or views and sounds of loading and unloading areas;*

**Analysis:** The proposed development is compatible with the character of the area, which is primarily retail, both large and small stores. The proposed building design is similar to the existing Brickyard center building and does not create any adverse impact on adjacent uses. The parking lot location, despite being in the front yard, reduces the need for a tall retaining wall along the front. This reduces the adverse visual impact and maintains compatibility with the area.

**Finding:** The project satisfies this standard.

- B. *Operating and delivery hours are compatible with adjacent land uses; and*

**Analysis:** This proposed retail use is similar in operating and delivery hours when compared with the other adjacent retail uses.

**Finding:** The project satisfies this standard.

- C. *The proposed design is compatible with the intensity, size, and scale for the type of use, and with the surrounding uses.*

**Analysis:** The proposed design is comparable and compatible with other similar auto parts retail uses in the city. The building design has been altered from the standard "Autozone" style to include more transparent glass and architectural features to more closely conform to

requirements of the CB district. The architectural style and materials are similar to the larger retail center, however the size, intensity, and scale of the proposed design is much smaller than the adjacent Brickyard center and more closely matches the size of the smaller retail uses along 3300 South.

**Finding:** The project satisfies this standard.

#### 4. Detriment to Persons or Property

The proposed use will not, under the circumstances of the particular case and the conditions imposed, be detrimental to the health, safety, and general welfare of persons, nor be injurious to property and improvements in the community, existing surrounding uses, buildings, and structures. The applicant shall demonstrate that the proposed use:

A. *Does not lead to deterioration of the environment by emitting pollutants into the ground or air that cause detrimental effects to the property or to neighboring properties;*

**Analysis:** The project involves a retail use which does not emit pollutants into the ground or air. No deterioration of the environment or detrimental effect to neighboring properties is expected.

**Finding:** The project satisfies this standard.

B. *Does not encroach on rivers or streams or direct run off into rivers or streams;*

**Analysis:** The project is not located next to a river or stream.

**Finding:** The project satisfies this standard.

C. *Does not introduce hazards or potentials for damage to neighboring properties that cannot be mitigated; and*

**Analysis:** Staff finds no aspect of the project that would damage neighboring properties.

**Finding:** The project satisfies this standard.

D. *Is in keeping with the type of existing uses surrounding the property, and that as proposed the development will improve the character of the area by encouraging reinvestment and upgrading of surrounding properties.*

**Analysis:** The existing surrounding uses are primarily retail in nature. As proposed, the development will improve this site, which has been vacant for a number of years and will encourage reinvestment and improvement of this area.

**Finding:** The project satisfies this standard.

#### 5. Compliance with Other Applicable Regulations

The proposed development complies with all other applicable codes and ordinances.

**Analysis:** Other than those modifications requested by the applicant, the proposed development complies with all other applicable codes and ordinances.

**Finding:** The project satisfies this standard.

### **Staff Analysis** (Planned Development in CB District; *Section 21A.54.150.E*)

Planned Developments within the CB zoning district may be approved subject to consideration of the following general conceptual guidelines (a positive finding for each is not required):

1. **Minimum Area:** *A planned development proposed for any parcel or tract of land under single ownership or control shall have a minimum net lot area for each zoning district as set forth in table [21A.54.150E2](#) of this section.*

**Analysis:** The CB district has no minimum lot size requirement for a planned development.

**Finding:** The project satisfies this standard.

2. **Density Limitations:** Residential planned developments shall not exceed the density limitation of the zoning district where the planned development is proposed. The calculation of planned development density may include open space that is provided as an amenity to the planned development. Public or private roadways located within or adjacent to a planned development shall not be included in the planned development area for the purpose of calculating density.

**Analysis:** The project is not a residential planned development.

**Finding:** This standard is not applicable.

3. **Consideration Of Reduced Width Public Street Dedication:**

**Analysis:** The project does not involve reduced width public street dedication.

**Finding:** This standard is not applicable.

4. **Planned Developments:**

- A. *The development shall be primarily oriented to the street, not an interior courtyard or parking lot.*

**Analysis:** 3300 South is considered the primary street for this development and is south of the site. Parking lots are proposed for the front (along 3300 South) and west side of the retail building. The proposed retail building will be primarily oriented toward the parking lot along 3300 South, between the building and 3300 South. The main building entrance faces south toward the parking lot and 3300 South. Moving the building toward the street would require significant re-grading of the site and would create an even taller retaining wall than proposed. Even though the parking lot is located in the front yard, the proposed site design is reasonable considering the topographical constraints of the pad site.

**Finding:** The project satisfies this standard.

- B. *The primary access shall be oriented to the pedestrian and mass transit.*

**Analysis:** The primary access is located on the building's south side, facing 3300 South. The pedestrian sidewalks and mass transit (bus) are both located along 3300 South. By locating the parking in front, the retaining wall along 3300 South is shorter than it would be if the building were located along the front property line. This layout creates a less imposing visual barrier than having a building directly atop a tall retaining wall. By utilizing existing sidewalks from 3300 South and providing additional sidewalks from the shopping center drive to the proposed building contributes to the pedestrian access for the site.

**Finding:** The project satisfies this standard.

- C. *The façade shall maintain detailing and glass in sufficient quantities to facilitate pedestrian interest and interaction.*

**Analysis:** The front façade of the proposed building (along 3300 South) will consist mainly of red brick and beige stucco, transparent glass and entry, and metal trellis work. The other facades lack any real windows but contain the same metal trellis work, brick work, and stucco as the front façade. The proposed design provides the described features in sufficient quantity to facilitate pedestrian interest.

**Finding:** The proposed building facades, without the required glass content, partially meet this standard; requiring the full 40% glass content would result in full compliance with this standard.

- D. *Architectural detailing shall emphasize the pedestrian level of the building.*

**Analysis:** The proposed brick work, building relief, and metal trellis architectural features of the building make steps to emphasize the pedestrian level of the building; however the project is clearly geared toward customers arriving in the vehicles to purchase parts and supplies for vehicles. This

detailing works for both driving customers and the small amount of pedestrian customers anticipated to access the business.

**Finding:** The proposed architectural detailing satisfies this standard.

- E. *Parking lots shall be appropriately screened and landscaped to minimize their impact on the neighborhood.*

**Analysis:** The parking lots will include landscaping to minimize potential impacts to the neighborhood. The Landscaping Ordinance stipulates a 7-foot perimeter parking lot buffer whenever the parking lot is within 20 feet of property lines. In one area of the site along the west edge, the landscape buffer proposed is approximately 5 feet rather than 7 feet. The requested reduction in landscape buffer width is minimal and adjoins vacant property that is considered undevelopable due to a fault line running through the property. The parking lot does not create any adverse impacts to the adjoining property or the neighborhood. The retaining wall separating the sidewalk and the parking lot will be terraced and landscaped to reduce its visual impact on vehicle and pedestrian traffic along 3300 South. The project should be held to the minimum 5% interior parking lot landscaping by adding 250 square feet additional landscaping to the parking areas – preferably the southern parking area, or by replacing the 12 parking stalls along 3300 South with landscaping.

**Finding:** As proposed, the project partially satisfies this standard; with the recommended conditions of approval, the project would fully satisfy this standard.

- F. *Parking lot lighting shall be shielded to eliminate excessive glare or light into adjacent neighborhoods.*

**Analysis:** The lighting proposed, via pole mounted and building mounted lights will be shielded and will not impact adjacent neighborhoods. The lighting will be similar to the existing lighting at adjacent commercial uses.

**Finding:** The parking lot lighting satisfies this standard.

- G. *Dumpsters and loading docks shall be appropriately screened or located within the structure.*

**Analysis:** The dumpster location will be screened by an enclosure and the receiving area will be located at the northwest corner of the building, out of view of the general public and not readily visible from the street.

**Finding:** The proposed redevelopment satisfies this standard.

- H. *Signage shall emphasize the pedestrian/mass transit orientation.*

**Analysis:** The front building façade along will contain the name “Autozone” in lighted letters and will comply with City sign ordinance regarding size. No other signs are proposed for the site. This combination emphasizes both the vehicle customers and the pedestrian/mass transit customers.

**Finding:** The proposed redevelopment satisfies this standard.

5. **Perimeter Setback:** The perimeter side and rear yard building setback shall be the greater of the required setbacks of the lot or adjoining lot unless modified by the planning commission.

**Analysis:** The project complies with the perimeter side and rear yard building setbacks.

**Finding:** The project satisfies this standard.

6. **Topographic Change:** The planning commission may increase or decrease the side or rear yard setback where there is a topographic change between lots.

**Analysis:** The project is proposed for a single existing lot and does not involve a topographic change between lots.

**Finding:** The project satisfies this standard.



## **Staff Analysis** (Planned Development – modifying regulations; *Section 21A.54.150.C*)

In approving any planned development, the planning commission may change, alter, modify or waive any provisions of this title or of the city's subdivision regulations as they apply to the proposed planned development. No such change, alteration, modification or waiver shall be approved unless the planning commission shall find that the proposed planned development:

1. *Will achieve the purposes for which a planned development may be approved pursuant to subsection A (planned development purpose statement) of this section (Section 21A.154);*

**Analysis:** The proposed planned development provides a logical approach to the use of the existing vacant site. The result is a development that is designed to accommodate both customers arriving in vehicles and on foot or mass transit. Strict application of the design requirements of the CB ordinance would result in a development that includes a tall, pronounced retaining wall along 3300 South, which is not a preferred outcome. With the recommended conditions of approval, the project will result in a creative approach to the use of land resulting in better design and development. The building design closely coordinates with styles and forms of the surrounding buildings. The landscape and site layout works to create a pleasing environment. The purposes of a planned development are as follows:

1. Creation of a more desirable environment than would be possible through strict application of other city land use regulations;
2. Promotion of a creative approach to the use of land and related physical facilities resulting in better design and development, including aesthetic amenities;
3. Combination and coordination of architectural styles, building forms and building relationships;
4. Preservation and enhancement of desirable site characteristics such as natural topography, vegetation and geologic features, and the prevention of soil erosion;
5. Preservation of buildings which are architecturally or historically significant or contribute to the character of the city;
6. Use of design, landscape or architectural features to create a pleasing environment;
7. Inclusion of special development amenities; and
8. Elimination of blighted structures or incompatible uses through redevelopment or rehabilitation.

**Finding:** The project satisfies the purposes 1, 2, 3, and 6 for planned developments.

2. *Will not violate the general purposes, goals and objectives of this title and of any plans adopted by the planning commission or the city council.*

**Analysis:** The proposed planned development achieves the purposes for which planned developments were instituted by allowing the Planning Commission to modify standards to encourage development of a site with topographical constraints, and does not detract from the general purposes of the zoning ordinance or any plans, master plans or otherwise, adopted by the planning commission or city council.

**Finding:** The project satisfies this standard.

## **Summary**

The Planned Development process is intended to provide flexibility in the application of site design in order to achieve a result more desirable than through strict application of City land use regulations. The proposed design achieves a compromise between pedestrian access, vehicle access, topography constraints, and compatibility with surrounding uses. By approving the proposed development, a site that has sat vacant for many years will be developed and done so in manner that will complement the adjacent uses. Realizing that the larger Brickyard center is not particularly pedestrian friendly, staff recommends a more comprehensive review of pedestrian facilities/improvements when the Brickyard center is redeveloped.

Planning Staff recognizes this site as a difficult site to develop and supports the proposed design with the design modifications requested by the applicant. Planning staff supports the project with the recommended conditions shown on the first page of this report.

*Original staff report*

**ATTACHMENT 'A'**

**APPLICANT'S PROJECT DESCRIPTION**

This pad has been for Lease or for sale in innumerable forms and variations over the past 25 years. From our history with marketing this pad, we have determined that we have a number of major obstacles to overcome.

The current zoning for this particular building pad is CB, while nearly everything surrounding it is CS and does not have the stringent guidelines dictating set back or glazing. The CB Zone requires the building to be set back no further than 16 feet from the road to make it more appealing to pedestrian traffic. We would like to propose that the building set back be waived in this instance for two reasons. First, 3300 South is not a pedestrian oriented thoroughfare. We do not have pedestrians roaming the streets actively looking for retail windows to browse, so no one is benefits from a pedestrian orientation. Second, the topography of the pad makes construction of a building within the 16 foot set back extremely cost prohibitive and aesthetically undesirable. In order to construct a structure in this location, we would need to take into consideration a grade change of 15 feet over a distance of 150 feet. This would require a retaining wall at least 10 feet tall next to the side walk to provide a flat enough grade on which to build. It would also require this wall to be structurally designed to create a structural bearing capacity for the building. If we are allowed to set the building back off the road as proposed, the building can be constructed close to grade and the retaining wall could be reduced to approximately 5 feet, allowing for some landscaping between the side walk and the wall.

Furthermore, in the CB zone, a requirement exists that the building be constructed with at least 40% of the store front surface area being non-reflective glazing also no exterior wall shall be built more than 15 feet long with the interruption of a window. Again, we are the only pad subject to these restrictions. The master plan of the city does not call for this, and the other properties surrounding this pad are in the less restrictive CS zone. Again we do not have the foot traffic, in our opinion, to justify this pad being held to these restrictions.

Auto Zone has modified its prototypical elevation to not only create visual continuity with the Brickyard Plaza, but to make the exterior of their building more inviting to those looking for the Brickyard Plaza while driving down 3300 South, thus creating a new retail presence.

We would request that the Planning Commission waive the set back requirement and the glazing requirement as indicated on the attached plans. We would also request a minor subdivision, handled on a staff level, to create a new tax parcel for the Auto Zone pad. The proposed description is attached.

*Original staff report*

**ATTACHMENT 'B'**

**SITE AND BUILDING DRAWINGS**



**dixon + associates**  
 architecture, planning, interiors  
 142 east 200 south, suite 202  
 salt lake city, utah 84111

CONSULTANTS

**BRICKYARD PLAZA**  
**3300 SOUTH**  
**HIGHLAND DRIVE**

**SALT LAKE CITY,**  
**UTAH**

#	DATE	DESC.

ISSUE:  
 PROJECT NO:  
 CAD DWG FILE:  
 DRAWN BY:  
 CHECKED BY:

SHEET TITLE

**BRICKYARD PLAZA**  
**SITE PLAN**  
**PROPOSED**

**A-1.0**



**DATA SUMMARY**

**TOTAL SQ. FT. = 304,593 S.F.**

**STALLS REQUIRED = 1,523 STALLS**  
**(5 STALLS/1,000 S.F.)**

**STALLS PROVIDED = 1,523 STALLS**

**\* MAJOR TENANTS IN OCCUPANCY**  
**AS OF MAY 2007**

SITE PLAN  
 SCALE: NOT TO SCALE

© COPYRIGHT 2007

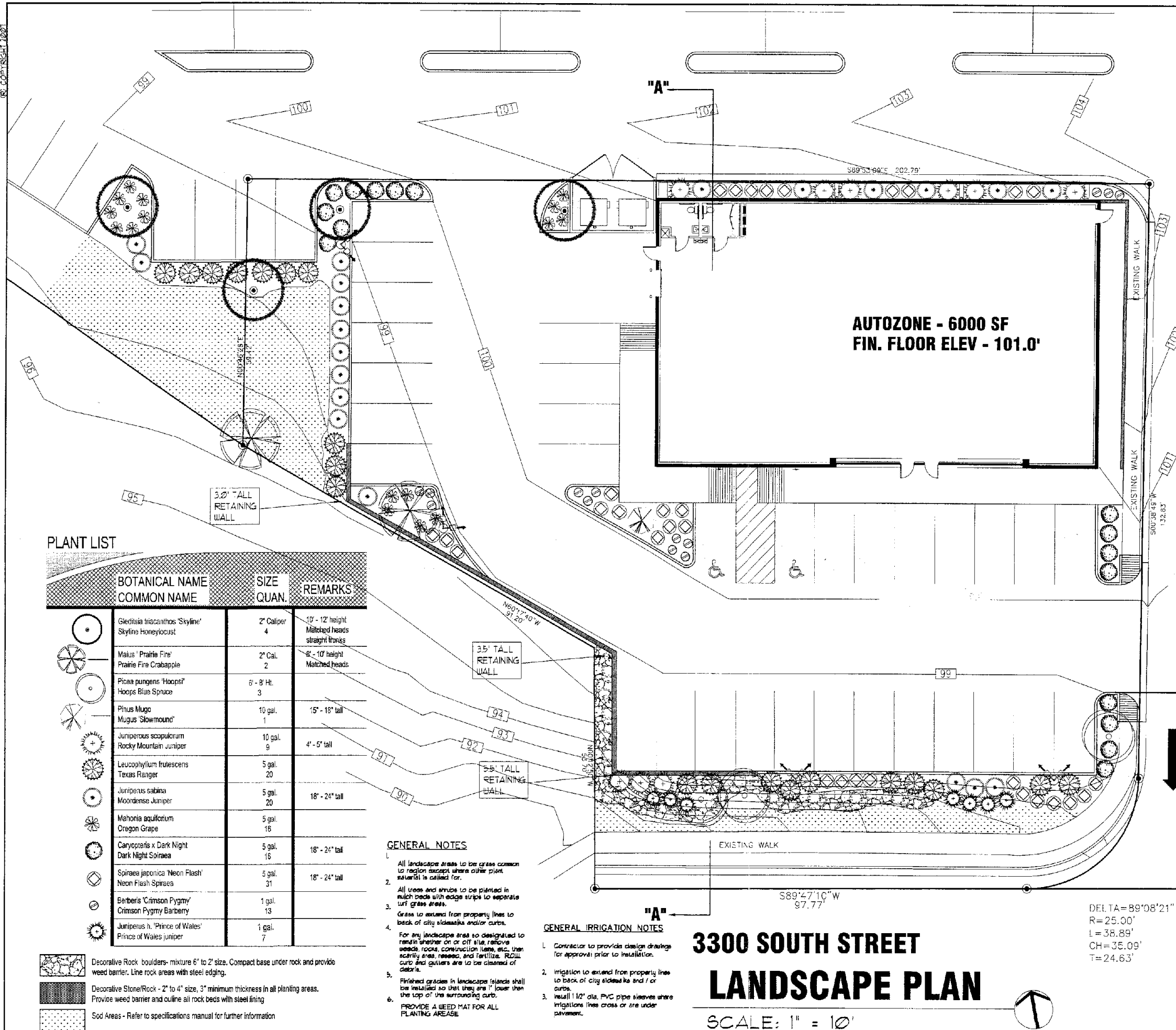

**PLANT LIST**

BOTANICAL NAME COMMON NAME	SIZE QUAN.	REMARKS
Gleditsia triacanthos 'Skyline' Skyline Honeylocust	2" Caliper 4	10' - 12' height Matched heads straight trunks
Malus 'Prairie Fire' Prairie Fire Crabapple	2" Cal. 2	8' - 10' height Matched heads
Picea pungens 'Hoops' Hoops Blue Spruce	6" - 8" Ht. 3	
Pinus Mugo Mugus 'Slowmound'	10 gal. 1	15" - 18" tall
Juniperus scopulorum Rocky Mountain Juniper	10 gal. 9	4' - 5' tall
Leucophyllum frutescens Texas Ranger	5 gal. 20	
Juniperus sabina Moordense Juniper	5 gal. 20	18" - 24" tall
Mahonia aquifolium Oregon Grape	5 gal. 16	
Caryopteris x Dark Night Dark Night Spiraea	5 gal. 16	18" - 24" tall
Spiraea japonica 'Neon Flash' Neon Flash Spiraea	5 gal. 31	18" - 24" tall
Berberis 'Crimson Pygmy' Crimson Pygmy Barberry	1 gal. 13	
Juniperus h. 'Prince of Wales' Prince of Wales juniper	1 gal. 7	

- Decorative Rock - boulders - mixture 6" to 2" size. Compact base under rock and provide weed barrier. Line rock areas with steel edging.
- Decorative Stone/Rock - 2" to 4" size, 3" minimum thickness in all planting areas. Provide weed barrier and outline all rock beds with steel lining
- Sod Areas - Refer to specifications manual for further information

- GENERAL NOTES**
- All landscape areas to be grass common to region except where other plant material is called for.
  - All trees and shrubs to be planted in mulch beds with edge strips to separate turf grass areas.
  - Grass to extend from property lines to back of city sidewalks and/or curbs.
  - For any landscape area so designated to remain weather on or off site, remove weeds, rocks, construction items, etc., then scarify area, reseed, and fertilize. Roll, curb and gutters are to be cleaned of debris.
  - Finished grades in landscape (islands) shall be related so that they are 1" lower than the top of the surrounding curb.
  - PROVIDE A WEED MAT FOR ALL PLANTING AREAS.

- GENERAL IRRIGATION NOTES**
- Contractor to provide design drawings for approval prior to installation.
  - Irrigation to extend from property lines to back of city sidewalks and / or curbs.
  - Install 1 1/2" dia. PVC pipe sleeves where irrigation lines cross or are under pavement.

**3300 SOUTH STREET  
LANDSCAPE PLAN**

SCALE: 1" = 10'

AMTEK or INTERCONTINENTAL locking valve box and cover

Pressure type vacuum breaker with valves

SHRUB PLANTING

TREE PLANTING

TREE STAKING AND GUYING

REG-FIL

REG-FIL

VACUUM

SARUB-PL

TREE-PL

STAKING

NTS

1	2	3
---	---	---

REVISIONS

4	13	6
---	----	---

AutoZone Store No. E181  
3300 SOUTH STREET  
SALT LAKE CITY UT  
LANDSCAPE PLAN

Architect: LEW ELLIS  
123 South Front Street  
Memphis, Tennessee 38103  
TEL: 495-8714 FAX: (901) 495-8969

04-09-08

L1

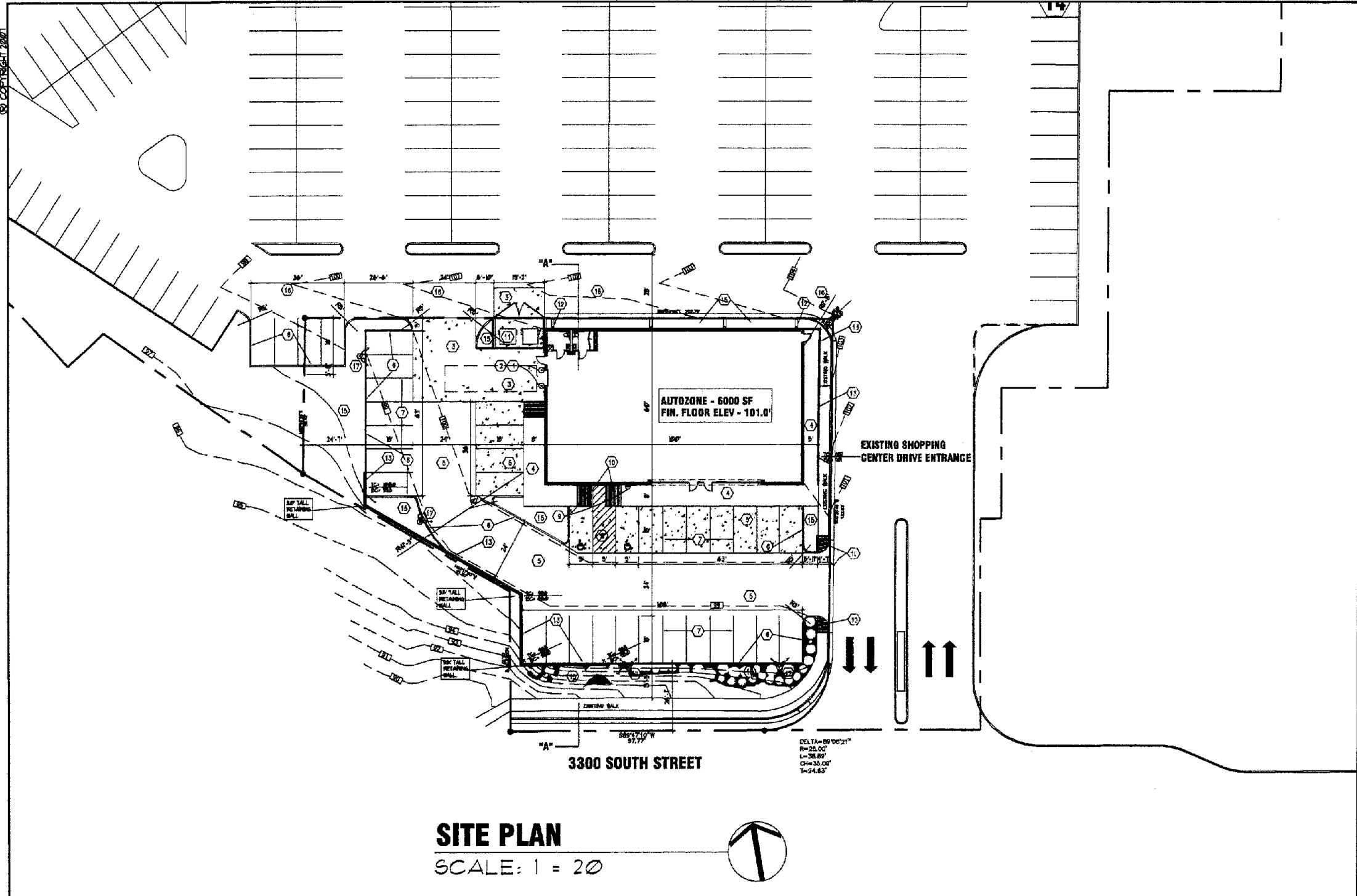

**BUILDING INFORMATION:**  
 OCCUPANCY - M - MERCHANTILE  
 TYPE OF CONSTRUCTION - VB  
 BUILDING SF - 6000 SF  
 SPRINKLERED - NO  
 FIRE ALARMS - NO  
 EMERGENCY LIGHTING - YES  
 NUMBER OF EXITS REQUIRED - 2  
 EXITS PROVIDED - 3  
 NUMBER OF FLOORS - 1 STORY  
 BUILDING HEIGHT - 21' MAIN PARAPET  
 PARKING SPACES REQUIRED 3/1000 = 18 SPACES  
 PARKING SPACES PROVIDED = 30  
 HC SPACES PROVIDED 2  
 TOTAL SPACES 32

- KEYNOTES**
- 1 PIPE GUARD
  - 2 LOADING DOOR
  - 3 CONCRETE LOADING AREA - 5" HEAVY DUTY CONCRETE
  - 4 NEW 4" THICK CONCRETE SIDEWALK
  - 5 5" CONCRETE PAVING
  - 6 CONCRETE CURB & GUTTER
  - 7 4" WIDE PARKING STRIPE PAINTED WHITE (TYP)
  - 8 4" WIDE DIAGONAL STRIPES PAINTED WHITE @ 2' O.C.
  - 9 ACCESSIBLE PARKING SIGN
  - 10 CONCRETE ACCESSIBLE RAMP - MAXIMUM SLOPE 1:12 (8.33%)
  - 11 TRASH ENCLOSURE
  - 12 ROOF DRAIN OUTLET LOCATION PROVIDE CONCRETE SPLASHBLOCK.
  - 13 POURED CONCRETE RETAINING WALL WITH HANDRAIL
  - 14 LANDSCAPE AREA
  - 15 NEW ASPHALT PAVING
  - 16 NEW SITE LIGHTS - 400W METAL HALIDE

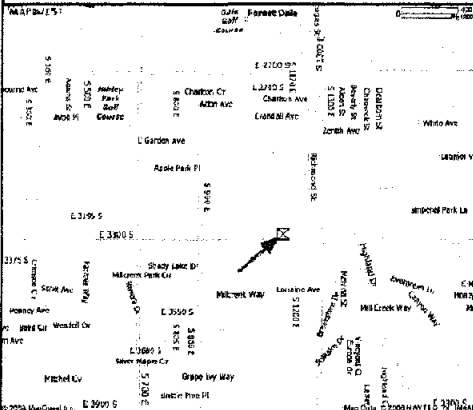

**SITE PLAN**  
 SCALE: 1 = 20

REVISIONS	4	5	6
1			
2			
3			

AutoZone Store No. E181  
 3300 SOUTH STREET  
 SALT LAKE CITY UT  
**ARCHITECTURAL SITE PLAN**

Architect: LEW ELLIS  
 123 South Front Street  
 Memphis, Tennessee 38103  
 TEL: 495-8714 FAX: (901) 495-8969

04-09-08

**C1**

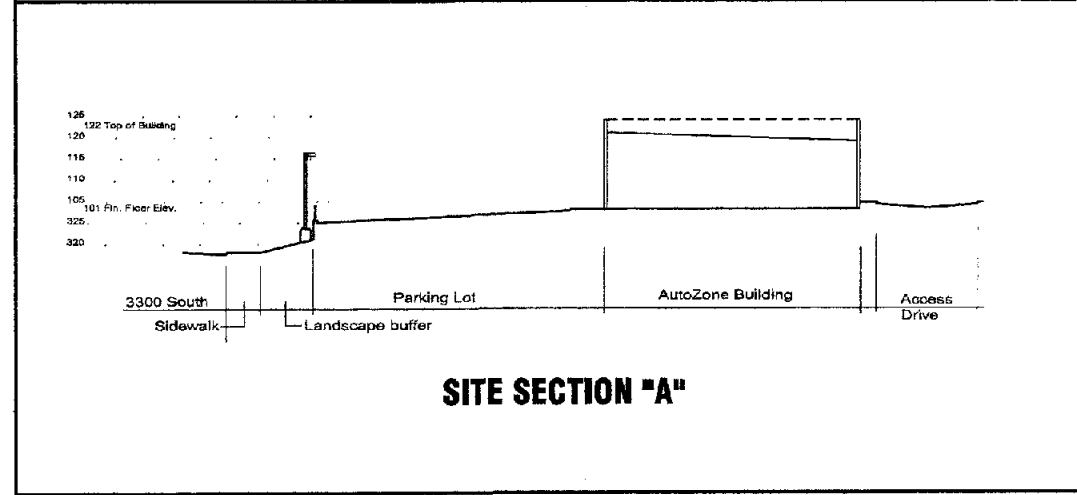

**PAD C - BRICKYARD PLAZA SHOPPING CENTER**  
 SALT LAKE CITY, UT.

**PARCEL DESCRIPTION:**

BEGINNING AT A POINT ON THE NORTH RIGHT OF WAY LINE OF 3300 SOUTH STREET, SAID POINT BEING SOUTH 00°02'10" WEST 1493.77 FEET AND SOUTH 89°47'10" WEST 1262.66 FEET FROM THE EAST QUARTER CORNER OF SECTION 29, TOWNSHIP 1 SOUTH, RANGE 1 EAST, SALT LAKE BASIN AND MERIDIAN, RUNNING THENCE SOUTH 89°47'10" WEST 97.78 FEET ALONG SAID RIGHT OF WAY LINE, THENCE NORTH 0°12'50" WEST 53.70 FEET, THENCE NORTH 80°17'40" WEST 91.20 FEET, THENCE NORTH 0°46'26" EAST 59.42 FEET, THENCE SOUTH 89°53'09" EAST 202.79 FEET, THENCE SOUTH 0°38'49" WEST 152.85 FEET TO A POINT ON A 25.00 FOOT RADIUS CURVE TO THE RIGHT, THENCE 38.88 FEET ALONG THE ARC OF SAID CURVE THROUGH A CENTRAL ANGLE OF 89°08'21" TO THE POINT OF BEGINNING.  
 CONTAINS 25,818 SQ. FT. OR 0.593 ACRES.

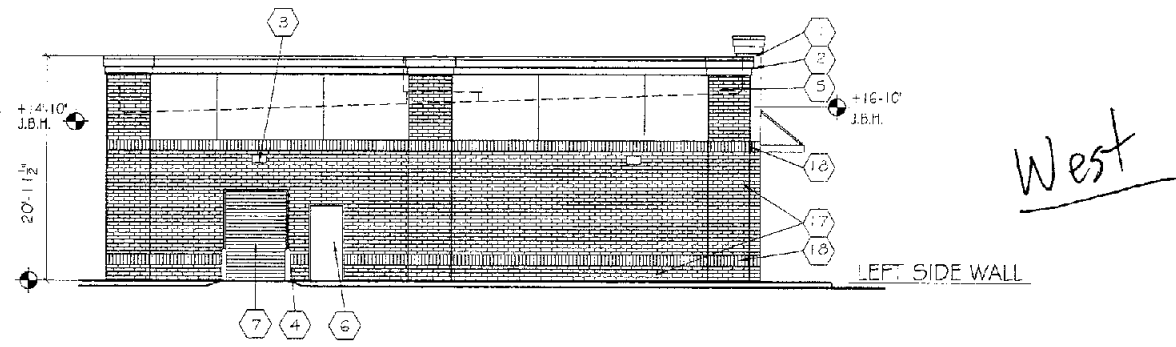
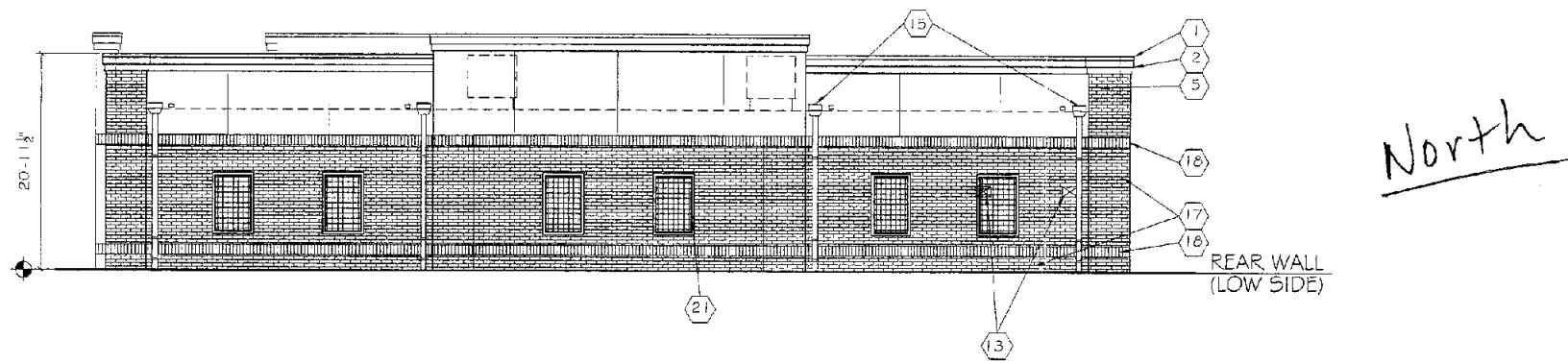
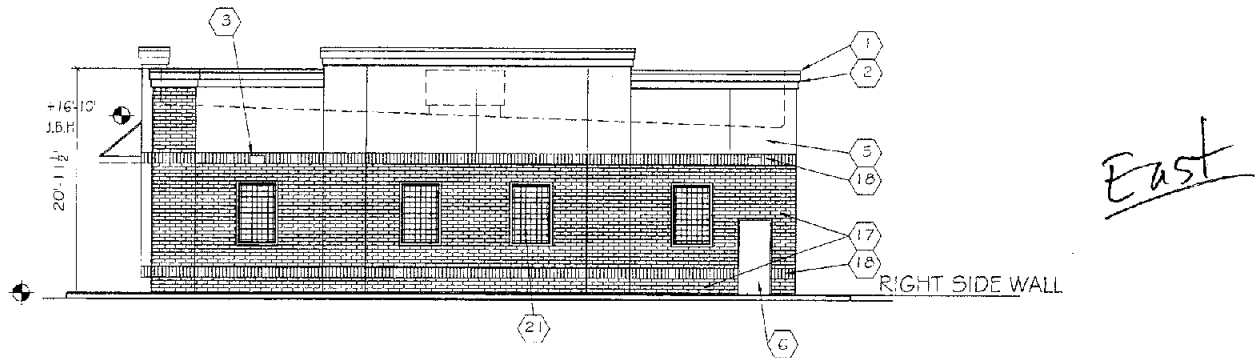
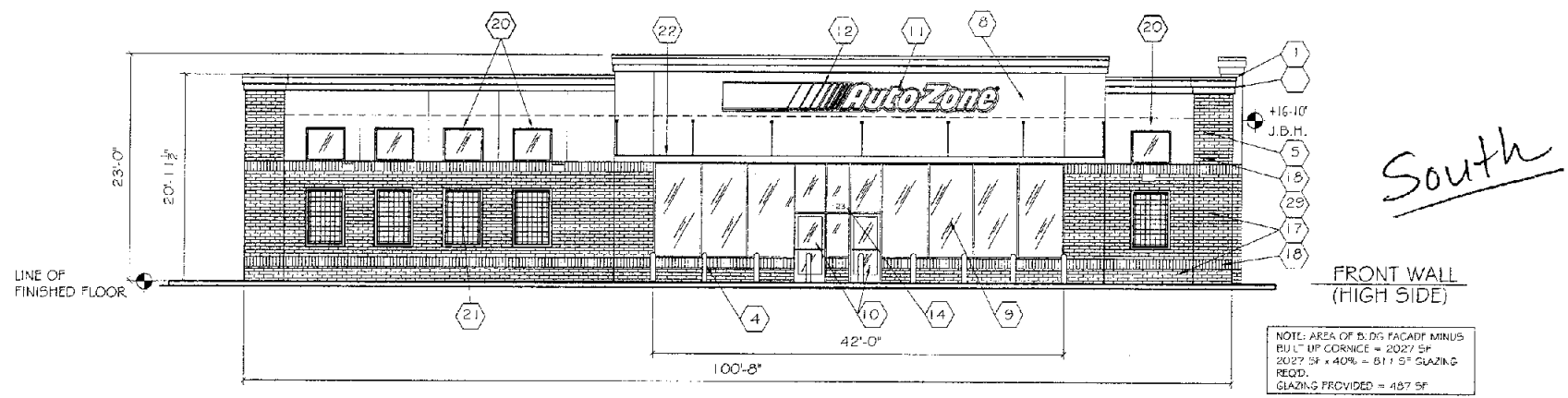

- 1 PREFINISHED ALUMINUM COPING COLOR: DARK BRONZE
- 2 DECORATIVE FOAM CORNICE WITH E.I.F.S. - COLOR: SW6091
- 3 WALL MOUNTED LIGHT FIXTURE
- 4 PIPE GUARD WITH RED SLEEVE
- 5 E.I.F.S. FINISH - COLOR: SW 6091 RELIABLE WHITE
- 6 PAINT HOLLOW METAL DOOR(S) RED WITH FRAMES BLACK.
- 7 PAINT METAL FRAMES BLACK. DO NOT PAINT ROLL UP DOOR.
- 8 E.I.F.S. - COLOR: SW 6091 RELIABLE WHITE
- 9 ALUMINUM STOREFRONT - RED KYMAR FINISH
- 10 GLASS AND ALUMINUM DOORS - CLEAR ANODIZED FINISH
- 11 WALL SIGN - 42" HIGH LETTERS - RED FACES
- 12 WALL SIGN - 42" HIGH STRIPES - ORANGE FACES
- 13 TOILET WALL VENTS PAINT TO MATCH WALL
- 14 STORE ADDRESS - 6" WHITE REFLECTIVE NUMBERS
- 15 SCUPPERS AND DOWNSPOUTS. PAINTED TO MATCH BACKGROUND WALL COLOR. ADJACENT 4" H. X 6" W. OVERFLOW SCUPPER. FLOWLINE 2" ABOVE ROOF.
- 16 BOND BEAM AT ROOF LINE
- 17 FIELD - UTILITY BRICK - RUNNING BOND
- 18 ACCENT - UTILITY BRICK - SOLDIER COURSE
- 19 1" V GROOVE SCORED JOINT (TYPICAL)
- 20 4' x 4' CLERESTORY WINDOWS. GLAZING AND FRAMES TO MATCH STOREFRONT SYSTEM
- 21 METAL TRELLIS WORK. PAINT DARK BRONZE
- 22 METAL AWNING - PAINT DARK BRONZE

NO SCALE  
AWN01A4U2  
ELEVATION KEY NOTES

**AUTOZONE, INC.**  
123 South Front Street  
Memphis, Tennessee 38103  
TEL: (901) 495-8714 FAX: (901) 495-8424

**AutoZone STORE DEVELOPMENT**

Prepared For: Store No. E181  
3300 SOUTH STREET  
SALT LAKE CITY UT

**EXTERIOR ELEVATIONS & NOTES**

REVISIONS	DATE	BY	SCALE
1.			AS NOTED
2.			
3.			
4.			

DATE: 04-14-08  
PROTOTYPE SIZE: 5W2-E  
**PS2**



*Original staff report*

**ATTACHMENT 'C'**

**SITE PHOTOGRAPHS:**

Looking east at front of site



Looking west at front of site



Looking north at existing Brickyard Center access driveway from 3300 South



Looking west at rear of site and adjoining parking lot north of site



Looking southwest at site



Looking southeast toward site from existing parking lot



Looking northwest at site from intersection of access driveway and 3300 South



Looking west at site from access drive median



*Original staff report*

**ATTACHMENT 'D'**  
**DEPARTMENT COMMENTS**

FIRE DEPARTMENT COMMENTS

**Stewart, Casey**

---

**From:** Itchon, Edward  
**Sent:** Friday, June 20, 2008 9:24 AM  
**To:** Stewart, Casey  
**Cc:** Montanez, Karleen; Butcher, Larry  
**Subject:** 1199 East 3300 South Auto Zone PD

Provide ifir hydrants within 400 feet of all exterior walls.

## ENGINEERING DEPT COMMENTS

**Stewart, Casey**

---

**From:** Smith, Craig  
**Sent:** Wednesday, July 02, 2008 10:07 AM  
**To:** Stewart, Casey  
**Subject:** RE: Autozone store at Brickyard Plaza

Casey-

I am familiar with this location. My only interest from Engineering is that I do a pre-inventory of all public way (curb, gutter, sidewalk) on 3300 South- other than that, Engineering is good to go.

---

**From:** Stewart, Casey  
**Sent:** Wednesday, July 02, 2008 9:54 AM  
**To:** Smith, Craig  
**Subject:** RE: Autozone store at Brickyard Plaza

Craig,

The attachments are all I have with the project at this point and I don't consider them to be civil plans. See what you can do with them at this point.

Thanks,

*Casey Stewart*  
Principal Planner, SLC Planning Division  
(801) 535.6260

---

**From:** Smith, Craig  
**Sent:** Wednesday, July 02, 2008 9:31 AM  
**To:** Stewart, Casey  
**Subject:** RE: Autozone store at Brickyard Plaza

Casey- I have not seen anything recently on a new Autozone building. I will be happy to respond from Engineering if I could get a set of civil plans.

---

**From:** Stewart, Casey  
**Sent:** Wednesday, July 02, 2008 9:19 AM  
**To:** Smith, Craig  
**Subject:** Autozone store at Brickyard Plaza

Craig,

I am working on a project for a proposed new Autozone building along 3300 South, near 1199 East (south entrance to Brickyard Plaza). Today is the final day for department comments. I will be discussing the project tonight with the Sugar House Community Council and was hoping to have all of the department comments with me. Are you able to provide those today yet?

Thanks,

*Casey Stewart*  
Principal Planner, SLC Planning Division  
(801) 535.6260  
[casey.stewart@slcgov.com](mailto:casey.stewart@slcgov.com)  
P.O. Box 145480  
Salt Lake City, UT 84114-5480

7/2/2008

**Stewart, Casey**

---

**From:** Walsh, Barry  
**Sent:** Thursday, June 19, 2008 6:08 PM  
**To:** Stewart, Casey  
**Cc:** Young, Kevin; Smith, Craig; Garcia, Peggy; Itchon, Edward; Butcher, Larry  
**Subject:** Pet 410-08-39  
**Categories:** Program/Policy

June 19, 2008

Casey Stewart, Planning

Re: Petition 410-08-39 Auto Zone Planned Development at 1199 E 3300 South (brickyard Plaza South Entrance)

The division of transportation review comments and recommendations are as follows:

Per our DRT review January 17, 2008 some of the issues were: grades and retaining walls, setbacks, right turn entry/exit only from the major brickyard entry drive, brick yard parking calculations cross easements and right of way dedications along 3300 South for pedestrian walk with in the public way. There are minor detail review items that will be covered in the final permit review process for ADA compliance – parking stalls, signs, ramps, etc.

Sincerely,

Barry Walsh

Cc Kevin Young, P.E.  
Craig Smith, Engineering  
Peggy Garcia, Public Utilities  
Ted Itchon, Fire  
Larry Butcher, Permits  
File

6/20/2008

BUILDING SERVICES DIVISION COMMENTS

**Stewart, Casey**

---

**From:** Walkingshaw, Nole  
**Sent:** Tuesday, June 24, 2008 7:11 AM  
**To:** Stewart, Casey  
**Cc:** Butcher, Larry  
**Subject:** 1199 E 3300 S Petition 410-08-39 Auto Zone

Casey,

Building services has the following Comments:

- Building Services found no concerns with the proposed relief from the set backs or glazing requirements in this instance.
- Building services recommends pedestrian walkways which inter-connect or enhance the existing pedestrian access, strengthening the pedestrian activity at the center.
- A complete Building and Zoning Review is required prior to permitting construction activities.

Thanks,  
Nole Walkingshaw

Nole Walkingshaw  
Salt Lake City Planning and Zoning  
Senior Planner  
801-535-7128



*Original staff report*

**ATTACHMENT 'E'**

**PUBLIC / COMMUNITY COUNCIL COMMENTS**

*Petition:*                   **Proposed Development for Autozone Store at Brickyard Plaza**  
  3300 South Street, Salt Lake City, UT  
Represented by: Nate Swain (Boyer Company)

Mr. Swain described the proposed 6,000 square foot retail footprint of the Autozone store to be located on 3300 South in the Brickyard Plaza. The developer is asking for relief from several design requirements of the CB District that the store is located within. They are asking that the 15 foot maximum setback be increased and that the percentage of transparent glass required for the street frontage of the store be reduced. It has been quite some time since this site had anything on it and the Boyer Company is having trouble finding interested parties to locate on this site.

*Trustee Comments:*

Cabot Nelson: Cabot does not like the blank walls on the non-street front sides and would like to see glass block or something that adds light and life to the other facades of the store. He would also like to see more brick articulation and detail to enliven the facades.

Grace Sperry: Grace questioned the need for the parking in the rear of the project since there is a tremendous amount of unused stalls for the south side of Brickyard Plaza. Mr. Swain stated that it is new parking required by the agreement with the retail tenants of the Brickyard Plaza.

Sarah Carlson: Sarah questions the need for an 11 foot retaining wall and wondered why the store is not oriented toward the ingress street or to the mall side.

Rawlins Young: Rawlins stated that the City's zoning ordinance requires a walkable area and why is the project not complying to make the site walkable (accessible) across the entire site. This Autozone project must facilitate access to the rest of the site and Brickyard Plaza.

Derek Payne: Derek stated that the City is invested in making projects within the CB zone scaled properly, a minimal setback from the sidewalk and with adequate visibility into the stores. This project does not meet any of these important zoning requirements. Although 3300 South is not a walkable street now, the City has to start somewhere and begin enforcing their own requirements in order to improve the walkability of the City.

Philip Carlson: Phil would like to see a mixed-use type project with multiple levels on the site that will generate a density and an increased level of street activity. This is the only way we can begin to make these parts of the City walkable.

*Summary:*

In a vote taken on the project, three (3) trustees were in favor of the development as proposed, eleven (11) were opposed to the development as it was presented.

*Original staff report*

**ATTACHMENT 'F'**  
**PC SUBCOMMITTEE NOTES**

## **Planning Commission Subcommittee**

**July 16, 2008**

### **Attendees:**

**Planning Commission:** Babs De Lay, Mary Woodhead, and Kathy Scott

**Planning Division Staff:** Casey Stewart

**Applicant:** Nate Swain; The Boyer Company

### **Background and Project Location: 1199 East 3300 South (Brickyard Plaza)**

**Presentation in summary including changes to the project:** The Boyer Company is requesting a Conditional Use approval for a Planned Development, which would include site development and a new building for an Autozone. Currently the property is zoned Community Business (CB).

The proposal is being processed through the Planned Development review because the applicant seeks relief from the following:

- The required maximum building front setback of 15 feet and the rear yard requirement of 10 feet.
- The required 40% glass content on the front building façade
- Parking lot setback requirements
- Maximum length of a blank wall (15 feet)
- Perimeter and interior parking lot landscaping
- Grade change limits

Mr. Stewart noted that the landscaping was less than the total 5% of the total parking area required by the ordinance and noted that the back strip does not count toward this.

Mr. Swain inquired if The Boyer Company added additional landscaping somewhere else in the Brickyard Plaza, could that count toward this calculation. The back of the building (north end) would also be landscaped to visually enhance the windowless back wall of the building.

Commissioners agreed that though it could not count, it was a good start for positive environmental changes to the Brickyard plaza, and would show the City that they were willing to upgrade the area.

Mr. Stewart noted that there was an approximately 15 foot grade change on the property; the applicant would place a terraced concrete retaining wall on 3300 South with landscaping as a buffer.

Mr. Swain stated that Autozone uses every inch of interior wall space for inventory; it would be hard to give that space up for glass windows, which is why they want to waive it. He stated that glass block could be used on the outside and lighted from the top and bottom to create the look of more glass.

Commissioners agreed that this was a good mitigation, and should not be a problem.

Commissioners commented that architecturally the design seemed to dry up along the north façade, and the building wall length without a break (glass, door, architectural feature) exceeds 15 feet.

Mr. Swain noted that there was not a door because the delivery access was on the side of the building, which was why they were using additional landscaping.

Mr. Swain stated that he had been working with Autozone and had encouraged them to use building materials to match their façade to the existing historic Brickyard Plaza structures.

Commissioners agreed that that this would help rejuvenate the backside of the Brickyard Plaza and they appreciated that the Mr. Swain was working with Autozone to help make this a more appealing project.

Commissioners inquired about traffic circulation. Mr. Swain noted that it would be a right in from the Brickyard property parking lot and right out onto 3300 South access.

**Conclusion:**

- **Commissioners agreed the grade change was not an issue.**
- **Commissioners agreed this development would be a huge improvement to the area, and hoped it was the start of a lot of positive changes to the area.**
- **Commissioners suggested using native and low water plants for the landscaping.**

*Original staff report*

**ATTACHMENT 'G'**

**PREVIOUS PROJECT APPROVED 2003**

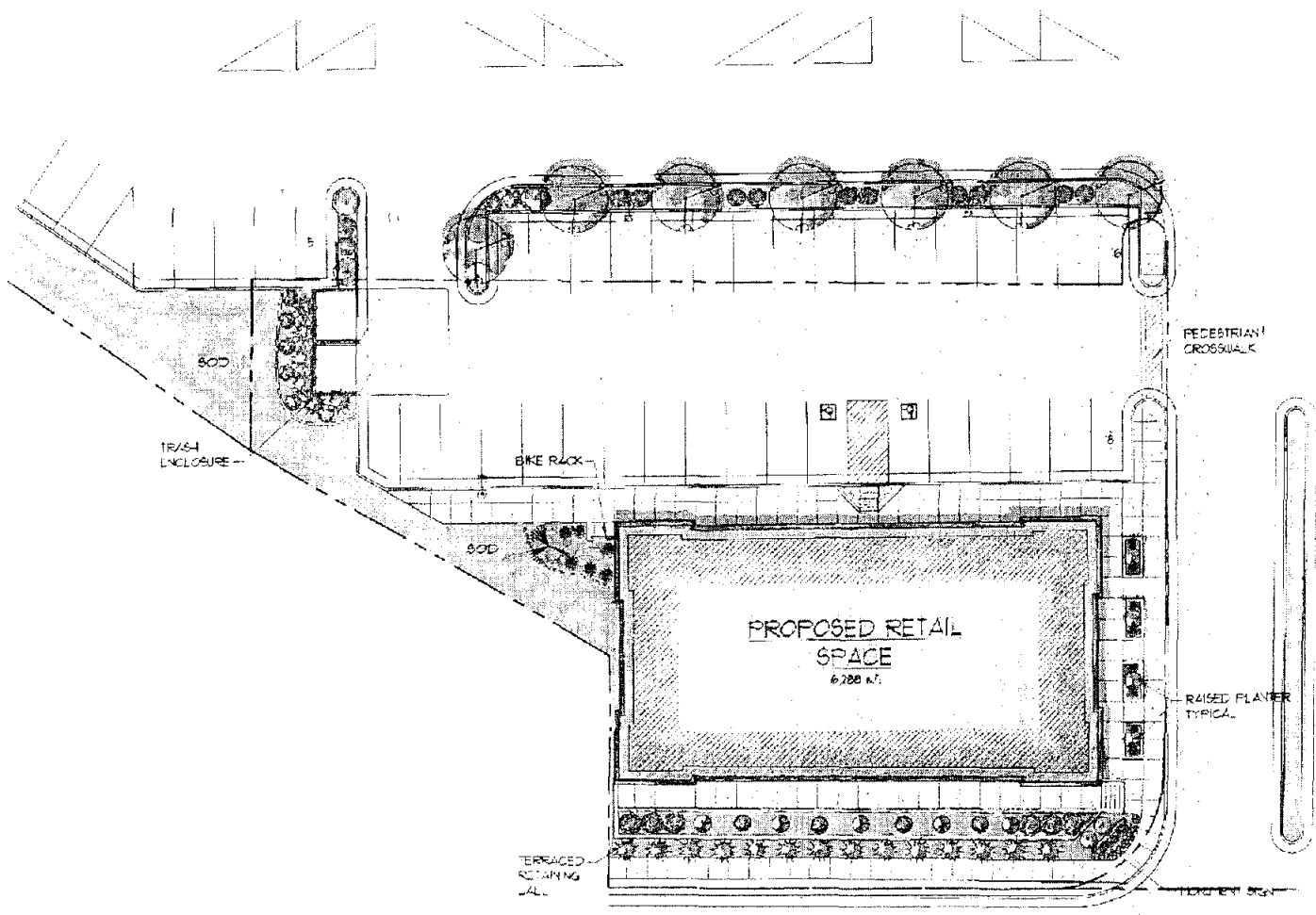

LANDSCAPE PLAN  
 SCALE 1/8" = 1'-0"



PROJECT/OWNER

**RETAIL SPACE  
 BRICKYARD PLAZA**

APPX. 1150 EAST 3300 SOUTH  
 SALT LAKE CITY, UTAH  
 JOHANSEN THACKERAY

ARCHITECT

**NICHOLS • NAYLOR**  
 ARCHITECTS

155 EAST WILMINGTON AVENUE SUITE 250  
 SALT LAKE CITY, UTAH 84108 (801) 487-3330



DATE

16 JANUARY 2002

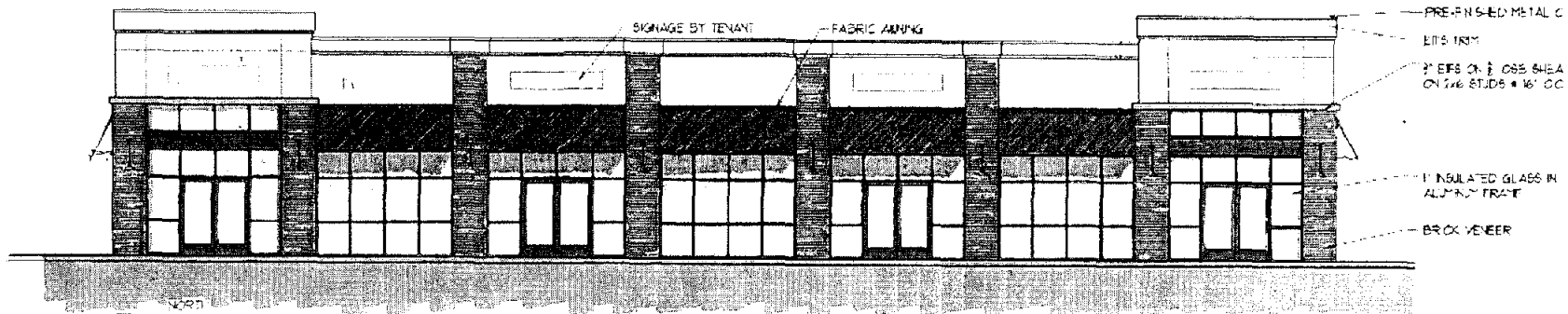

PROJECT/OWNER

**RETAIL SPACE  
BRICKYARD PLAZA**

APPX. 1150 EAST 3300 SOUTH  
SALT LAKE CITY, UTAH  
JOHANSEN HACKERAY

ARCHITECT

**NICHOLS • NAYLOR**  
ARCHITECTS

1155 EAST WASHINGTON AVENUE SUITE 250  
SALT LAKE CITY, UTAH 84106 (801) 487-3330



DATE

16 JANUARY 2002

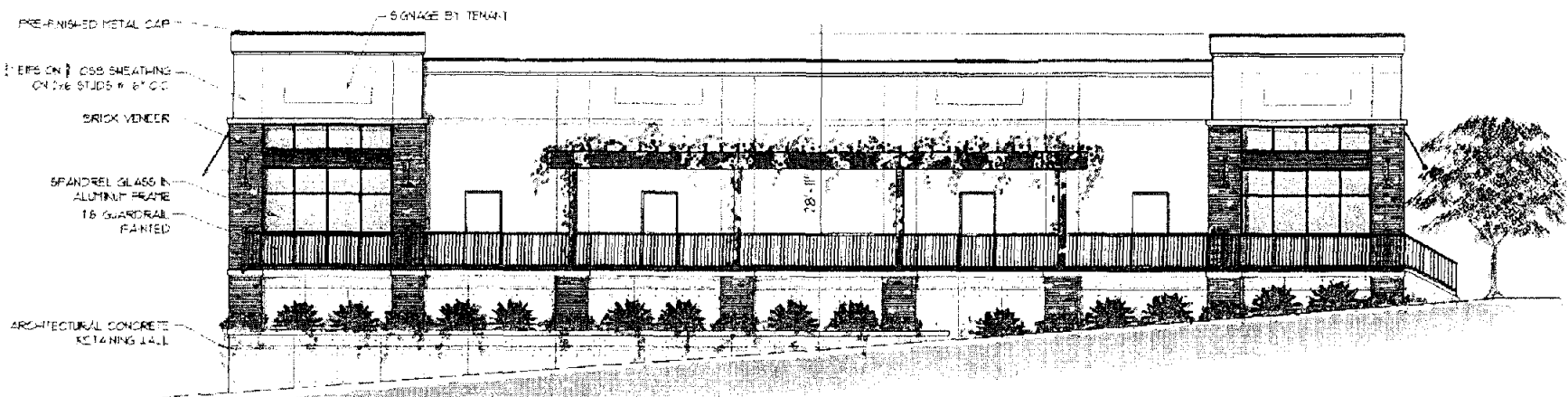

NORTH  
**1 ELEVATION**  
SCALE: 1/8" = 1'-0"

SOUTH  
**4 ELEVATION**  
SCALE: 1/8" = 1'-0"